

GEOLOGIC REPORT 57

SURVEY-MONITORING SYSTEM, PILLAR MOUNTAIN LANDSLIDE AREA,  
KODIAK, ALASKA

By  
Randall G. Updike

---



---

FAIRBANKS, ALASKA  
1988

STATE OF ALASKA

Bill Sheffield, *Governor*

Esther Wunnicke, *Commissioner, Dept. of Natural Resources*

Ross G. Schaff, *State Geologist*

IN MEMORIAM

REUBEN KACHADOORIAN  
March 30, 1921 - June 30, 1983

*Reuben Kachadoorian played a key role in the identification and geotechnical study of the Pillar Mountain landslide. He had a long and colorful career working on a wide variety of other projects in Alaska, including engineering studies of the Denali Highway, the Cape Lisburne area, and the Trans-Alaska Pipeline route. His 30 years of research in the state has done much to further the knowledge of Alaskan geology. At the time of his death, Kachadoorian was geologist-in-charge of the Branch of Alaskan Geology, U.S. Geological Survey, Menlo Park, California.*

*This professional report is dedicated to an outstanding scientist and an inspiring friend.*

*Randall G. Updike  
August 1, 1983*

*Cover photo: Unstable Pillar Mountain poses potential hazard to City of Kodiak (right foreground). Slope instability is indicated by scars and by material from former landslides. Abert Highway at base of mountain; photo shows former highway bisected by debris from major rockfalls in late 1971. St. Paul Harbor in foreground. (Photo courtesy of U.S. Geological Survey; file no. PJO 78-33.)*

## CONTENTS

	Page
Introduction . . . . .	1
Geology of Pillar Mountain . . . . .	1
DGGS investigations . . . . .	1
Installation of system . . . . .	3
Survey procedures . . . . .	4
Survey results . . . . .	5
Statistical inferences from survey data . . . . .	5
Alternative methods . . . . .	8
Observations . . . . .	8
Conclusions . . . . .	8
Acknowledgments . . . . .	8
References cited . . . . .	10
Appendix A - Survey coordinates . . . . .	Envelope

## FIGURES

Figure	1. Diagrammatic map showing relative location of base stations and reference points . . . . .	2
	2. Typical open fissures regarded as active, intermediate slope of Pillar Mountain . . . . .	3
	3. Survey station 1, typical of station installations . . . . .	3
	4. Installation design, observation stations on Pillar Mountain . . . . .	4
	5. View from intermediate slope, Pillar Mountain, looking toward Near Island and Gull Island . . . . .	5
	6. Apparent strain path of survey station 1 in the horizontal plane . . . . .	9
	7. Apparent strain path of survey station 2 . . . . .	10
	8. Apparent strain path of survey station 3 . . . . .	10
	9. Apparent strain path of survey station 4 . . . . .	11
	10. Apparent strain path of survey station 5 . . . . .	11
	11. Apparent strain path of survey station 6 . . . . .	11
	12. Apparent strain path of survey station 7 . . . . .	11
	13. Apparent strain path of survey station 8 . . . . .	12
	14. Apparent strain path of survey station 9 . . . . .	12
	15. Apparent strain path of survey station 10 . . . . .	12
	16. Apparent strain path of survey station 11 . . . . .	12
	17. Apparent strain path of survey station 12 . . . . .	12
	18. Apparent strain path of survey station 13 . . . . .	13
	19. Apparent strain path of survey station 14 . . . . .	13
	20. Apparent strain path of survey station 15 . . . . .	13
	21. Apparent strain path of survey station 16 . . . . .	13
	22. Apparent strain path of survey station 17 . . . . .	13
	23. Apparent strain path of survey station 18 . . . . .	13
	24. Apparent strain path of survey station 19 . . . . .	14
	25. Apparent strain path of survey station 20 . . . . .	14
	26. Apparent strain path of survey station 21 . . . . .	14
	27. Apparent strain path of survey station 22 . . . . .	14
	28. Apparent strain path of survey station 23 . . . . .	14
	29. Apparent strain path of survey station 24 . . . . .	14
	30. Apparent strain path of survey station 25 . . . . .	15
	31. Apparent strain path of survey station 26 . . . . .	15
	32. Apparent strain path of survey station 27 . . . . .	15
	33. Apparent strain path of survey station 28 . . . . .	15
	34. Apparent strain path of survey station 29 . . . . .	15
	35. Apparent strain path of survey station 30 . . . . .	15

**CONTENTS (cont.)**

36. Apparent strain path of survey station 31. . . . .	16
37. Apparent strain path of survey station 32. . . . .	16
38. Apparent strain path of survey station 33. . . . .	16
39. Apparent strain path of survey station 34. . . . .	16
40. Apparent strain path of survey station 35. . . . .	16

**TABLE**

Table 1. Calculated variances, in feet, of north-south (N), east-west (E), and vertical (V) components from the initial measurements of October 30-31, 1978, for each survey station. . . . .	6
---	---

**PLATE**

Plate 1. Station positions, Pillar Mountain slide area, Kodiak, Alaska . . . . .	Envelope
--	----------

## SURVEY-MONITORING SYSTEM, PILLAR MOUNTAIN LANDSLIDE AREA, KODIAK, ALASKA

By  
Randall G. Updike<sup>1</sup>

### INTRODUCTION

For nearly two centuries, the community of Kodiak has prospered around Saint Paul Harbor, which is dominated by 1,270-ft-high Pillar Mountain located immediately to the northwest.

Site of a destructive tsunami generated by the Prince William Sound Earthquake of 1964, Saint Paul Harbor has been the focal point of commerce for Kodiak since 1792, when Alexander Baranov, manager of the Shelikov (later Russian American) Company, selected the site as a fur-trading center because of "its good harbor and close vicinity to good building timber" (U.S. Bureau of Census, 1983, p. 74). The city now hosts a vigorous fishing economy.

Pillar Mountain borders Saint Paul Harbor and rises to a northeast-southwest trending ridge over 1,250 ft high (pl. 1). The steep, harbor-facing slope of the mountain has a long history of localized ground failure. Slope instability appears to have increased over the last 25 yr, due in part to excavation and construction at the mountain base.

Although Pillar Mountain was quarried for road and construction materials through the late 1960s, the Abert Highway (fig. 1) was moved from the lower slope to the base of Pillar Mountain in the late 1950s because of slope instability. In December 1971, major rockfalls closed the highway.

At the time of this accelerated mass wasting, the Alaska Department of Highways (now the Department of Transportation and Public Facilities, or 'DOT') contracted R&M Consultants, Inc., of Anchorage, to establish and survey monuments on the mountain slope. R&M conducted these surveys in December 1971 (after the rockfall), July 1972, and October 1972.

In the fall of 1972, DOT installed two slope-indicator casings in drill holes on the intermediate and lower slopes of the mountain. With the acquired data, DOT contracted Dames and Moore, Inc., to conduct a geotechnical investigation of the slide area (Murphy, 1973).

In 1976, the slope-indicator casings were reoccupied and the monuments were resurveyed by the U.S. Geological Survey and DOT. Kachadoorian and Slater (1978)

reported that progressive slope movement had occurred since 1971-72 and that landslides on Pillar Mountain could range from small-scale failures typical of the mountain to a rapid rock slide large enough to cause a destructive sea wave in Saint Paul Harbor. Such a wave could inflict damages to Kodiak as severe as those of the tsunami from the 1964 earthquake. Consequently, the Director of the USGS, in a May 10, 1978, letter of advisement, warned the Alaska State Geologist of the potential geologic hazard to Saint Paul Harbor and the city of Kodiak (Menard, 1978). Because of this, DGGs began monitoring Pillar Mountain in October 1978.

### GEOLOGY OF PILLAR MOUNTAIN

Topography, rock types, and bedrock structure contribute significantly to the instability of Pillar Mountain. The glacially oversteepened slope rises more than 2:1 (horizontal to vertical) and in places reaches 1:2. Bedrock consists of interbedded phyllite and graywacke of the Kodiak Formation (Cretaceous), and both bedding and foliation dip steeply toward the northwest. Multiple joint sets penetrate the bedding. At least two thrust faults strike east-northeast across the mountain slope, dipping to the northwest at angles that appear shallower than those of the bedding. Younger dip-slip faults, striking northeast and northwest, cut across the bedding and the thrust faults. No direct evidence for Holocene activity along these faults has been observed. Numerous surface lineaments that appear over much of the mountain slope strike nearly parallel to the bedding and joints. Fissuring parallels the trends defined by bedrock structure; some lineaments probably represent former fissures.

### DGGs INVESTIGATIONS

On August 23 and 24, 1978, I accompanied State Geologist R.G. Schaff and M. Bukovansky (geotechnical engineer) and D. Jones (coastal engineer), both of Dames and Moore, Inc., on a helicopter and ground reconnaissance of the southeastern slopes of Pillar Mountain. We observed indications that the surface material of the slope was moving. Numerous ground fissures were evident between the top of the 1971 slide scar and the summit. Disruption of soil and vegetation and the

<sup>1</sup>DGGs, P.O. Box 772116, Eagle River, Alaska 99577.

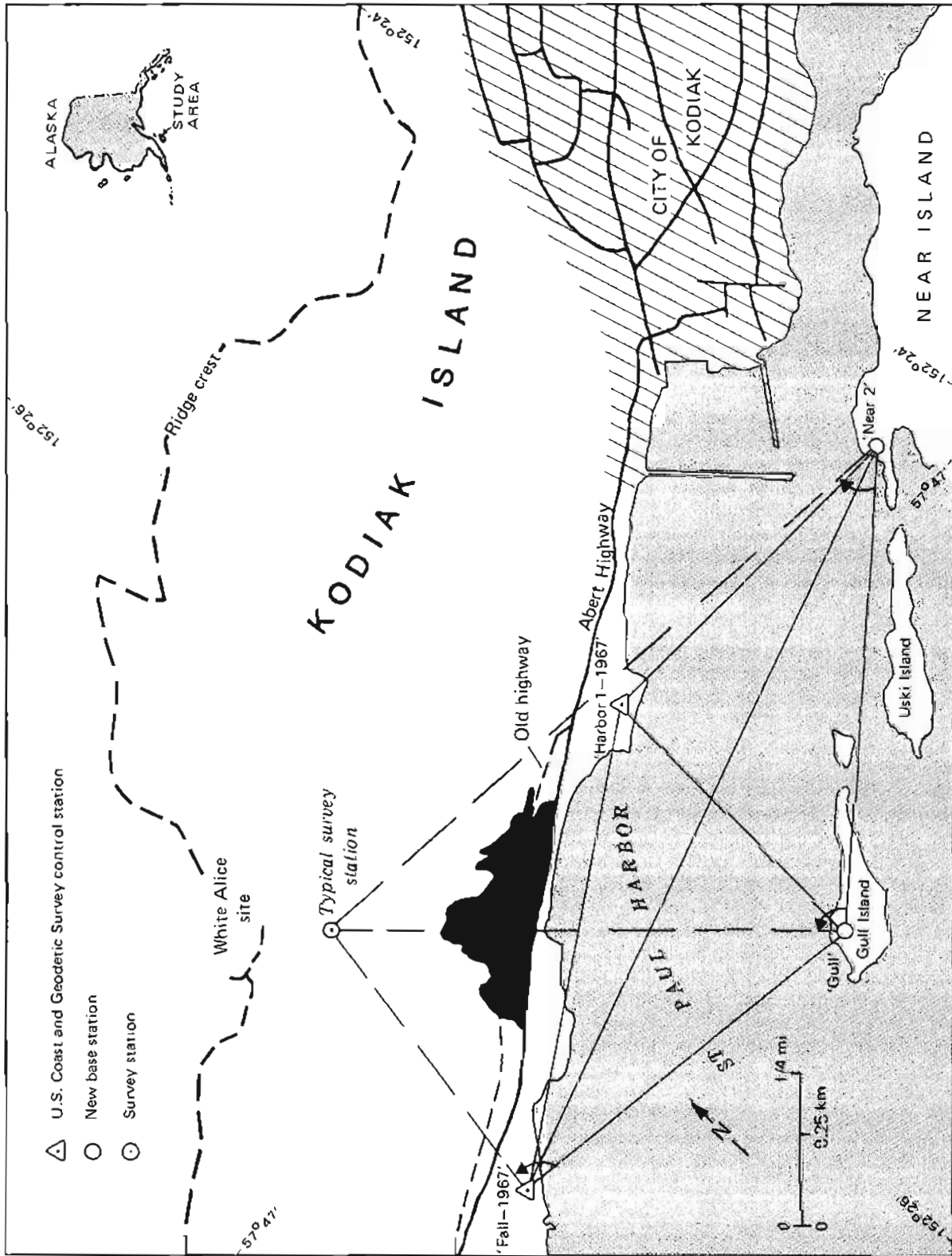

Figure 1. Diagrammatic map showing relative location of base stations and reference points.



Figure 2. Typical open fissures regarded as active; intermediate slope of Pillar Mountain.

abrupt angular configuration of the many open fissures (fig. 2) indicate that they are active. Soil infilling and revegetation suggest that some fissures have been stable for several years. The configuration of the fissures is dictated by separation of bedrock along bedding and joint planes.

The field party concluded that a toppling-type failure was occurring over most of the mountain slope and that it was caused by gravity-induced separations along closely spaced metamorphic-rock cleavage that dips into the mountainside at a steep angle. Water entering and reemerging along structural lineaments also appeared to contribute to slope failure.

The depth to which bedrock is affected by the failure process and the rate of surface movement could not be determined. The field party agreed that if toppling is a shallow phenomenon, there is far less concern for a catastrophic landslide than had been previously contemplated. However, we felt that the observable features (including recent rockfalls) and the survey data reported by the U.S. Geological Survey (Kachadoorian and Slater, 1978) were enough to warrant additional study.

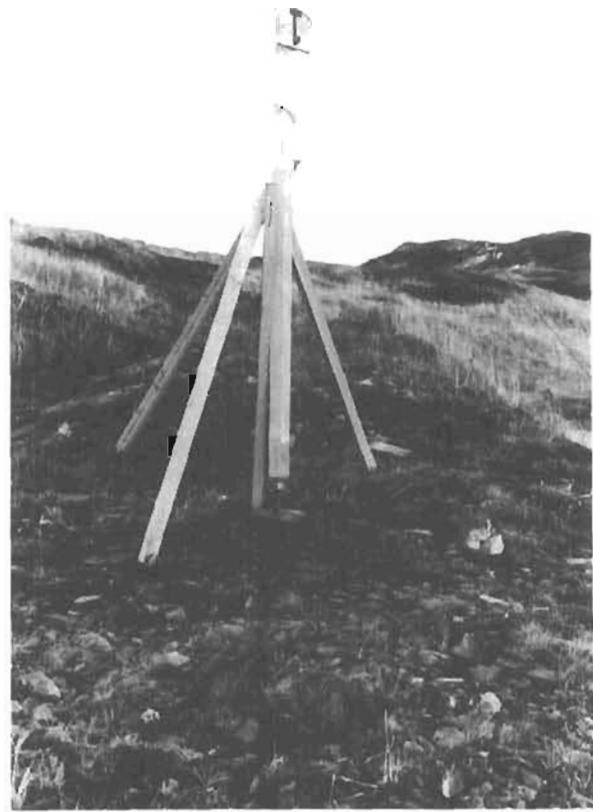

Figure 3. Survey station 1, typical of station installations

In 1978 Schaff secured state funds to install and operate a new survey monitoring system (fig. 3). A registered surveyor in Kodiak, Roy Ecklund, was contracted to operate the system.

#### INSTALLATION OF SYSTEM

On October 4 and 5, 1978, Ecklund, J.R. Newgaard (DGGS), and I made several traverses of the mountainside and selected sites for monitoring the potential slide mass delineated by Kachadoorian and Slater (1978). Points were selected at the summit near open fissures and at locations (stations 1, 2, and 5) both east and west of the delineated slide zone (stations 14 and 22) (fig. 1). Three points (stations 25-27) were located directly above the slide scarp and another (station 33) was positioned in the southwestern bedrock face of the scarp.

Ecklund supervised the construction of permanent survey stations at the selected points (figs. 1 and 4). Climatic conditions--intense freeze-thaw cycles, high

winds, occasional heavy snowfall--warranted unusual care in the installation of monuments. The stations consist of 5/8-in.-diam rebar, 24 in. long, set 20 in. into the ground, with at least 12 in. of the rod embedded in rock and reinforced with concrete (fig. 4). Before each set of readings was taken, the mountain was traversed and the integrity of each monument was confirmed.

Base stations were established across Saint Paul Harbor at Gull and Near Islands (stations 'Gull' and 'Near 2'). Concrete pads at each base station were poured directly onto bedrock to support the tripod with theodolite. The stations were established by triangulation expansion from U.S. Coast and Geodetic Survey (USCGS) stations 'Fall-1967' and 'Harbor 1-1967'

(fig. 1, pl. 1). The control figures consisted of one adjusted quadrilateral based on the zone 5 state plane inverse between the USCGS stations. Elevations of 'Gull' and 'Near 2' were established by reciprocal leveling from 'Fall-1967' with an NI-025 Zena automatic level (accuracy,  $\pm 0.025$  ft/0.6 mi).

#### SURVEY PROCEDURES

The 'Gull' and 'Near 2' stations, 4,167.19 ft apart, form the base line of the survey network (fig. 5). During the initial survey, the state plane coordinates of the two stations were established (pl. 1). All measurements were made with 010 and 010A Zena theodolites (average

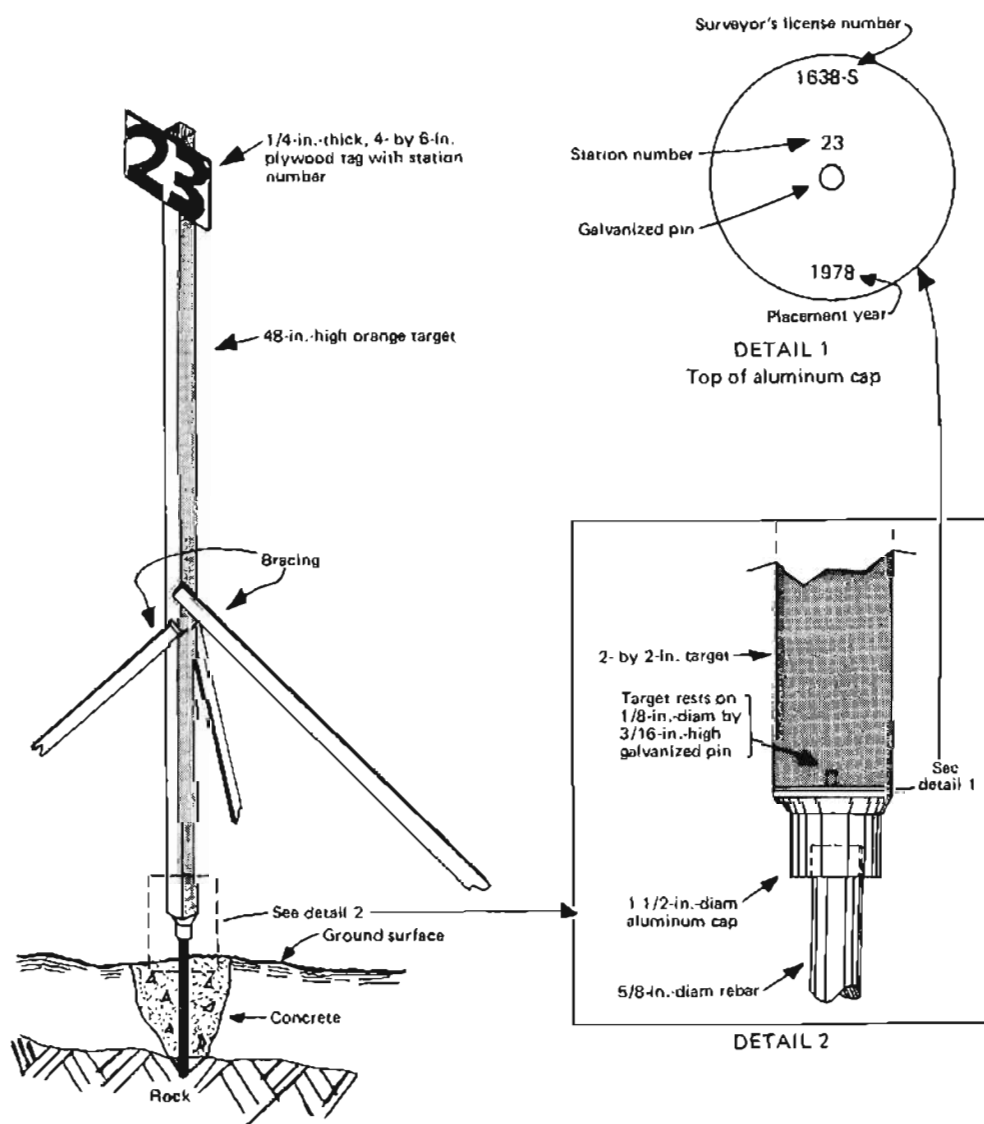

Figure 4. Installation design, observation stations on Pillar Mountain.





Figure 5. View from intermediate slope, Pillar Mountain, looking toward Near Island (left) and Gull Island (right), where base stations were located. Note survey station in foreground (center). Kodiak harbor headwater at extreme left.

directional error of  $\pm 1$  sec, direct and reversed positions). Horizontal angles for the initial and subsequent survey sets were turned with station 'Fall-1967' as a backsight. Two survey sets were turned to each point by using the 'Near 2' and 'Gull' stations, and the mean of the two balanced sets was used to calculate the bearing-bearing intersection. Two sets of vertical angles were taken to each point from 'Gull' only, and the mean of the two balanced sets was used to establish the elevations of the point. No curvature or refraction correction was computed. Wind, tidal effects, low winter sun angle, and varied surface conditions (ice, snow, and rain) undoubtedly introduced some random or systematic errors for a given data set.

#### SURVEY RESULTS

Eight sets of readings were made from October 30, 1978, to June 24, 1980, when the project was terminated. Appendix A shows the computed north-south and east-west bearing values (tied to the state plane coordinate system) and vertical elevations. Vertical elevations are not given for the readings of May 2-3, 1980, because surface refraction introduced significant errors (Ecklund, personal commun., 1980).

During the summer of 1979, K.W. Wong, a photogrammetric and geodetic engineer, was contracted by the City of Kodiak on the advice of the Pillar Mountain Landslide Geotechnical Committee to evaluate the data generated by this study and by previous surveying projects. Wong noted (and I agree) that two difficulties are inherent in the survey method (above) used by DGCS to gather data: "the method did not provide any redundancy in determining either the horizontal or vertical positions of the points during each survey";

also, the instrumentation used had a low limit of distance-measuring accuracy.

Wong (1979, p. 11) felt that survey precision could be improved by more refined instrumentation. However, the levels of precision he suggested far exceeded the scope and funding of the project.

#### STATISTICAL INFERENCES FROM SURVEY DATA

To assess the survey data acquired (app. A) for actual movement of the points, a statistical analysis of the recorded numbers was made to minimize random or systematic errors in data acquisition. The following method, suggested by Wong (1979, p. 25), was used.

The earliest sets of measurements were made in a 5-wk period: October 30, November 14, and December 1, 1978. Assuming that the points did not move during this period and that any differences in coordinate readings were caused by survey errors, Wong calculated the root-mean-square error of the changes in coordinates as:

$$\begin{aligned}\sigma_{\Delta N} &= \pm 0.05 \text{ ft} \\ \sigma_{\Delta E} &= \pm 0.08 \text{ ft} \\ \sigma_{\Delta h} &= \pm 0.06 \text{ ft} \\ \sigma_{\Delta R} &= \pm 0.09 \text{ ft}\end{aligned}$$

Where  $\sigma_{\Delta N}$  represents changes in north coordinates,  $\sigma_{\Delta E}$  represents changes in east coordinates,  $\sigma_{\Delta h}$  is the change in elevation, and  $\sigma_{\Delta R}$  represents changes in the resultant vector of the three components.

Using the same assumptions on the three initial sets of readings, I also calculated the maximum mean-

Table 1. Calculated variances, in feet, of north-south ( $\Delta N$ ), east-west ( $\Delta E$ ), and vertical ( $\Delta h$ ) components from the initial measurements of October 30-31, 1978, for each survey station.

Station	November 14, 1978			December 1, 1978			March 16, 1979		
	$\Delta N$	$\Delta E$	$\Delta h$	$\Delta N$	$\Delta E$	$\Delta h$	CN	$\Delta E$	$\Delta h$
1	-0.02	-0.19	+0.18	+0.01	-0.22	+0.17	+0.10	-0.05	+0.04
2	-0.06	-0.07	+0.05	-0.05	-0.03	+0.06	-0.05	-0.27	+0.03
3	-0.05	-0.03	+0.05	+0.02	-0.11	+0.10	+0.07	-0.29	+0.01
4	-0.10	+0.05	0	-0.04	+0.04	+0.08	-0.06	-0.09	+0.11
5	-0.14	+0.20	-0.03	-0.14	+0.23	+0.05	-0.10	+0.01	+0.18
6	0	0	+0.08	-0.04	+0.04	-0.01	-0.03	-0.20	+0.14
7	-0.05	+0.12	+0.06	-0.04	+0.14	+0.05	-0.06	+0.02	+0.06
8	-0.05	-0.05	+0.16	-0.10	+0.02	+0.08	-0.02	-0.13	+0.10
9	+0.06	-0.10	+0.10	-0.05	-0.06	+0.13	+0.09	-0.28	+0.18
10	+0.05	-0.06	+0.13	+0.03	-0.17	+0.16	+0.11	-0.28	+0.23
11	-0.01	-0.04	+0.06	-0.01	-0.13	+0.04	+0.06	-0.16	+0.06
12	-0.03	-0.05	+0.05	0	-0.05	+0.02	-0.05	-0.10	+0.01
13	+0.02	-0.07	+0.07	+0.03	+0.20	0	0	0.08	-0.02
14	+0.01	-0.07	+0.04	+0.01	-0.12	+0.05	-0.02	-0.08	+0.01
15	-0.14	+0.06	-0.19	-0.07	-0.07	-0.13	-0.12	+0.02	-0.17
16	-0.01	-0.05	+0.08	+0.01	0	+0.02	-0.03	-0.03	+0.03
17	0	0	+0.06	+0.02	-0.07	0	-0.03	-0.01	-0.02
18	+0.05	-0.03	+0.09	+0.07	-0.06	+0.11	+0.08	-0.06	+0.15
19	+0.06	-0.04	+0.05	+0.08	-0.17	+0.02	+0.02	-0.07	+0.05
20	+0.05	+0.01	+0.01	+0.09	-0.08	+0.01	+0.03	+0.03	-0.03
21	+0.04	+0.03	+0.01	+0.02	-0.04	-0.03	+0.03	0	+0.01
22	-0.06	+0.07	-0.08	-0.01	-0.07	-0.01	-0.03	+0.03	-0.06
23	-0.06	+0.05	+0.08	+0.07	-0.16	+0.10	-0.04	-0.04	+0.08
24	-0.09	+0.06	-0.07	-0.01	-0.07	-0.01	-0.06	+0.02	0
25	-0.06	-0.04	+0.08	+0.01	-0.20	+0.03	-0.07	-0.20	+0.01
26	-0.05	-0.04	+0.06	+0.02	-0.13	+0.02	-0.07	-0.14	0
27	+0.01	-0.03	0	+0.06	-0.13	-0.02	-0.01	-0.08	-0.05
28	-0.02	0	+0.02	-0.02	-0.10	-0.02	-0.05	-0.10	-0.03
29	0	-0.02	+0.05	-0.02	-0.09	-0.04	-0.01	-0.11	+0.07
30	+0.02	-0.04	+0.03	-0.03	-0.07	+0.01	-0.08	-0.03	+0.02
31	-0.03	-0.01	-0.05	+0.01	-0.12	+0.03	+0.01	-0.15	+0.06
32	0	-0.01	0	-0.04	-0.03	-0.03	-0.05	0	-0.02
33	+0.04	-0.01	+0.04	-0.07	+0.06	-0.01	-0.03	+0.08	-0.01
34	+0.05	0	+0.04	-0.01	-0.01	0	+0.01	+0.03	+0.04
35	+0.02	+0.02	0	-0.04	-0.01	+0.01	+0.01	+0.01	+0.06

Table 1. (cont.)

Station	April 23, 1979			May 2, 1980			June 23, 1980		
	$\Delta N$	$\Delta E$	$\Delta h$	$\Delta N$	$\Delta E$	$\Delta h^a$	$\Delta N$	$\Delta E$	$\Delta h$
1	+0.40	-0.55	+0.19	+0.14	-0.20		+0.38	-0.21	+0.17
2	+0.21	-0.25	+0.03	+0.02	-0.07		+0.16	-0.01	-0.01
3	+0.27	-0.20	+0.05	+0.02	-0.06		+0.41	-0.10	+0.03
4	+0.17	-0.16	+0.09	+0.08	+0.01		+0.19	+0.20	-0.01
5	+0.13	+0.03	+0.14	+0.05	+0.10		+0.35	+0.10	+0.12
6	+0.13	-0.01	+0.08	+0.15	+0.02		+0.33	+0.03	+0.06
7	+0.05	+0.02	+0.07	+0.10	-0.11		+0.11	+0.24	-0.02
8	+0.08	-0.19	+0.09	+0.08	-0.12		+0.09	+0.30	-0.05
9	+0.22	-0.31	+0.12	+0.30	-0.26		+0.28	+0.12	+0.09
10	+0.22	-0.21	+0.04	+0.14	-0.14		+0.10	+0.35	-0.06
11	+0.03	-0.16	+0.03	+0.18	-0.18		+0.11	+0.20	-0.03
12	-0.12	+0.04	-0.05	+0.10	-0.08		+0.04	+0.25	-0.12
13	+0.10	-0.25	+0.05	-0.01	+0.09		+0.06	+0.28	-0.09
14	+0.09	-0.26	+0.05	+0.04	0		+0.08	+0.22	0
15	-0.02	-0.18	+0.05	-0.07	+0.07		-0.04	+0.30	-0.24
16	+0.05	0.22	0	+0.06	-0.07		+0.10	+0.18	-0.08
17	-0.02	-0.05	0				-0.11	+0.20	+0.07
18	+0.10	-0.07	-0.06	+0.04	-0.02		-0.01	+0.08	+0.04
19	+0.15	-0.17	-0.02	+0.10	+0.02		+0.17	+0.19	-0.05
20	+0.12	-0.07	-0.01	+0.11	+0.04		+0.18	+0.19	-0.05
21	+0.06	+0.03	-0.05	-0.01	+0.11		+0.09	+0.25	-0.10
22	+0.12	-0.14	-0.35	+0.08	-0.05		+0.09	+0.24	-0.13
23	+0.05	-0.16	+0.01	-0.03	+0.03		+0.14	+0.06	0
24	+0.01	-0.06	-0.04	-0.10	+0.15		+0.06	+0.20	-0.12
25	-0.02	-0.14	-0.05	-0.05	-0.06		-0.05	+0.13	-0.13
26	+0.04	-0.11	+0.02	-0.04	-0.03		-0.06	+0.08	-0.14
27	+0.08	-0.10	-0.01	+0.04	-0.04		+0.05	+0.09	-0.09
28	+0.07	-0.08	+0.02	+0.04	-0.04		+0.06	+0.12	-0.11
29	+0.12	-0.07	+0.04	+0.17	-0.07		+0.07	+0.16	+0.01
30	+0.09	-0.08	+0.04	+0.03	+0.11		+0.02	+0.19	-0.10
31	+0.12	-0.12	+0.05	+0.04	+0.03		+0.08	+0.10	-0.06
32	+0.09	-0.03	-0.01	-0.07	+0.01		-0.04	+0.04	-0.08
33	-0.30 <sup>b</sup>	+0.19 <sup>b</sup>	-0.11 <sup>b</sup>	-0.01	+0.14		+0.02	0	-0.18
34	+0.13	-0.10	0	+0.02	+0.01		+0.08	-0.03	-0.07
35	+0.01	+0.01	-0.01	-0.05	+0.09		+0.01	+0.04	-0.09

<sup>a</sup>Vertical elevation not taken because of error from surface refraction.  
<sup>b</sup>Pin bent by falling rock prior to this date.

expected random error, equal to  $\pm 3\sigma$  (third degree of deviation from the mean), which indicates that there is only a 0.2 percent chance that the actual random error exceeds the  $3\sigma$  value. This calculation, reiterated for the three data sets, provides the following mean maximum error values:

$$3\sigma_{\Delta N} = \pm 0.16 \text{ ft}$$

$$3\sigma_{\Delta E} = \pm 0.26 \text{ ft}$$

$$3\sigma_{\Delta h} = \pm 0.20 \text{ ft}$$

These values are thus taken to represent the major, intermediate, and minor axes for the error ellipsoid at a survey point. Error levels for stations near the mountain summit are increased by the variation in sighting distance between points near the mountain summit and base, abrupt change in vertical angles being turned, increased refraction effect for altitudes, and angle of incident light.

Calculated variances from original coordinates for each survey station are given in feet in table 1. Negative values indicate changes in opposite direction; thus, -0.02 under 'N' denotes a movement of 0.02 ft to the south.

The apparent strain paths in the horizontal plane for each station are given in figures 6-40. The initial point is the origin for each graph and each point on the plotted curve correlates---with one exception---with subsequent variances from the initial coordinates. (Variances for July 6, 1979, are consistently out of context with both earlier and later readings; these data are not plotted on the figures.) The calculated mean error ellipse for the entire station array is superimposed on figures 6-40, with axes established by the preceding calculations.

#### ALTERNATIVE METHODS

I considered two alternative methods for obtaining the error ellipses. The first would consider each point independent of the rest of the station array and base the error ellipse axes on the three initial (late-1978) sets of readings for that point. This method would be based on but three numbers (statistically weaker than using the entire station array) and would negate consideration of systematic errors inherent in the data set.

The second alternative would place stations in three groups on the basis of elevation---upper, intermediate, and lower---and then calculate the deviations therein. This method would presume that three groups of relative accuracy exist. However, it is far more probable that progressive variation with distance from the baseline is the case. Thus, neither alternative portrays the probable error at a given station as fully as does the method I actually used (see preceding section).

#### OBSERVATIONS

On the basis of the data acquired and the statistics calculated, the following observations can be made:

- . The curves for stations at or near the summit are more eccentric than those for lower stations.
- . Of the 35 stations, 24 show a deflection in coordinates from northwest to southeast between April 23, 1979, and May 2, 1980.
- . For the last set of readings (June 23, 1980), 26 stations recorded a pronounced shift toward the east, often larger than all previous readings combined.
- . Stations 3, 5, 6, and 9 had the most atypical curves (figs. 8, 10, 11, and 14).
- . Those stations positioned at locations not near fissures (figs. 6, 7, 10, 19, and 27) show curves similar to nearby stations.
- . Those stations directly above the slide scar (figs. 30-32) showed no evidence of atypical behavior.
- . Station 3 (fig. 38), located in the rock face of the active slide area, showed no evidence of movement.

#### CONCLUSIONS

Three conclusions can be made. First, the data indicate that virtually no movement occurred from November 1978 to July 1980. Second, the statistical calculations and station graphs support the accuracy of the first three movements (late 1978) and thereby help establish a reliable data network for future research. Third, the inherent limitations of the survey method and the difficulties associated with climate and topography introduced errors in all readings. Introducing a correction factor to screen out these consistent errors is beyond the scope of this project. Therefore, before further readings are taken on the stations, I recommend that:

- a) An electronic distance-measuring instrument be used with the 1<sup>o</sup> theodolite.
- b) Redundancy be incorporated into the survey procedures. (This can be done by using the 'Near 2' base station and adding a third, possibly on Uski Island; fig. 1.)
- c) Control stations well outside the potential slide zone be established. (These should include points on the summit of Pillar Mountain, points on the mountain slopes several tens of meters to the east and west, and stations in the highway and dock areas. Points at the White Alice site at the mountain summit should also be referenced.)

#### ACKNOWLEDGMENTS

This project was supported through a special appropriation from the State of Alaska to the Division of Geological and Geophysical Surveys. Roy Ecklund, Registered Land Surveyor, Kodiak, Alaska, conducted the survey of stations we established. I particularly ap-

preciate the careful technical reviews of this report by James Riehle of the U.S. Geological Survey (Anchorage), and Gail March of DGGs. Jay Newgaard, DGGs, Anchorage, assisted the author in the field. I also appreciate the various members of the DGGs Publications staff who participated in various phases of production:

S.A. Jacques, M.E. Pritchard, M.A. Armstrong, and F.L. Larson.

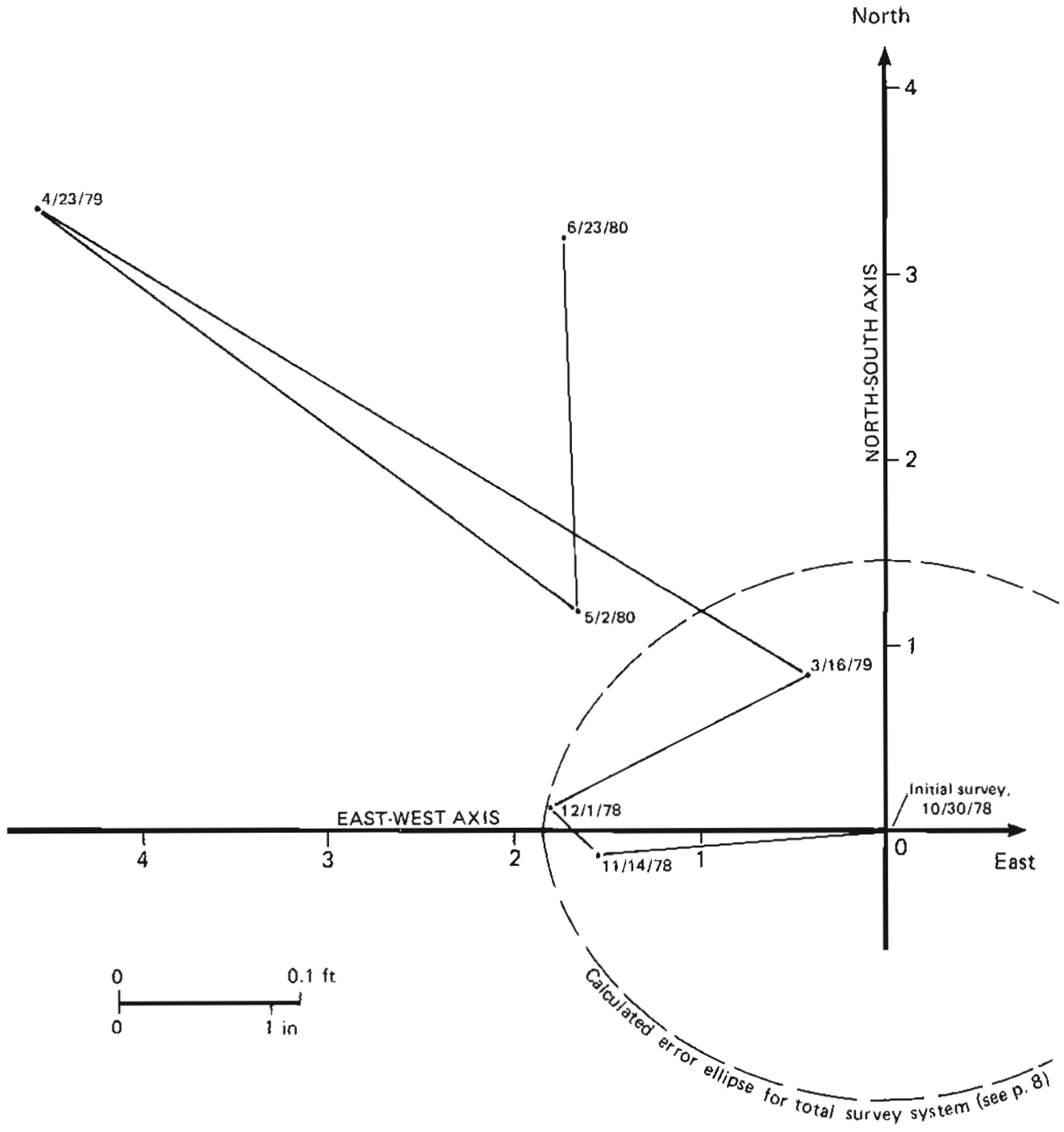

Figure 6. Apparent strain path of survey station 1 in the horizontal plane.

## REFERENCES CITED

- Kachadoorian, Reuben, and Plafker, George, 1967, Effects of the earthquake of March 27, 1964, on the community of Kodiak and nearby islands: U.S. Geological Survey Professional Paper 542-F, p. F1-41.
- Kachadoorian, Reuben, and Slater, W.H., 1978, Pillar Mountain landslide, Kodiak, Alaska: U.S. Geological Survey Open-file Report 78-217, 21 p.
- Menard, H.W., 1978, Letter of advisement to the Alaska State Geologist: U.S. Geological Survey, Reston, Virginia, May 10.
- Murphy, W.J., 1973, Consultation and geotechnical investigation of Pillar Mountain slide, Kodiak, Alaska: Anchorage, Dames and Moore, Inc., unpublished report, 17 p.
- U.S. Bureau of the Census, 1983, Report of population and resources of Alaska at the 11th census: Washington, U.S. Government Printing Office, 282 p.; reissued as Historical Miscellaneous Document 340, pt. 7, U.S. 52nd Congress, first session.
- Wong, K.W., 1979, Evaluation of ground survey program and surface movement on Pillar Mountain slide: Bloomington, Indiana, Kam W. Wong, Consulting Engineer, unpublished report, 67 p.

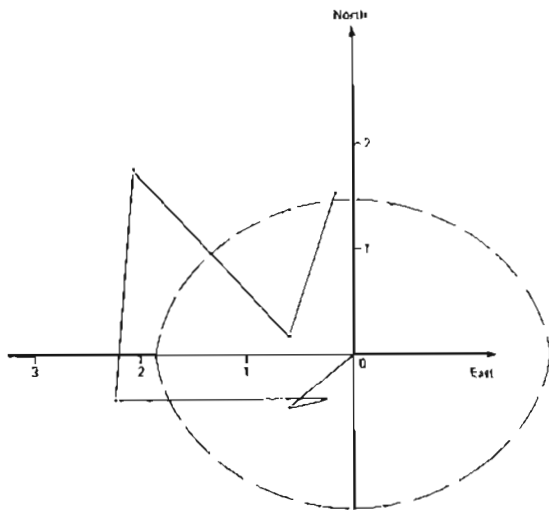

Figure 7. Apparent strain path of survey station 2.

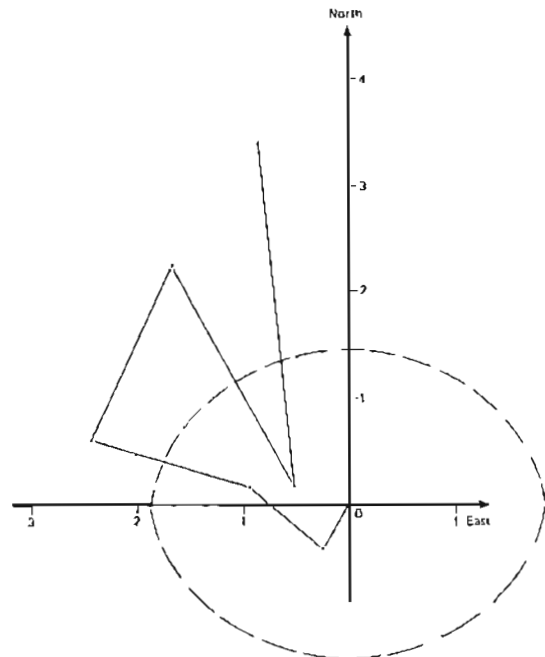

Figure 8. Apparent strain path of survey station 3.

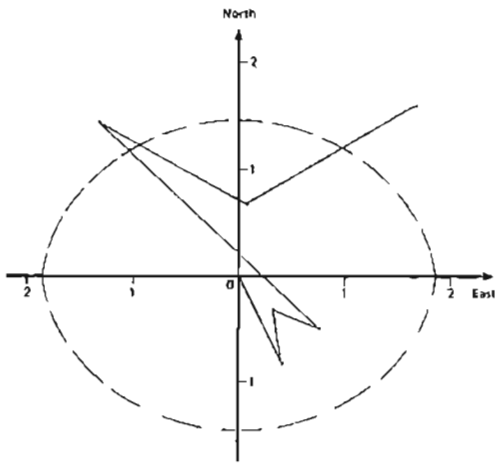

Figure 9. Apparent strain path of survey station 4.

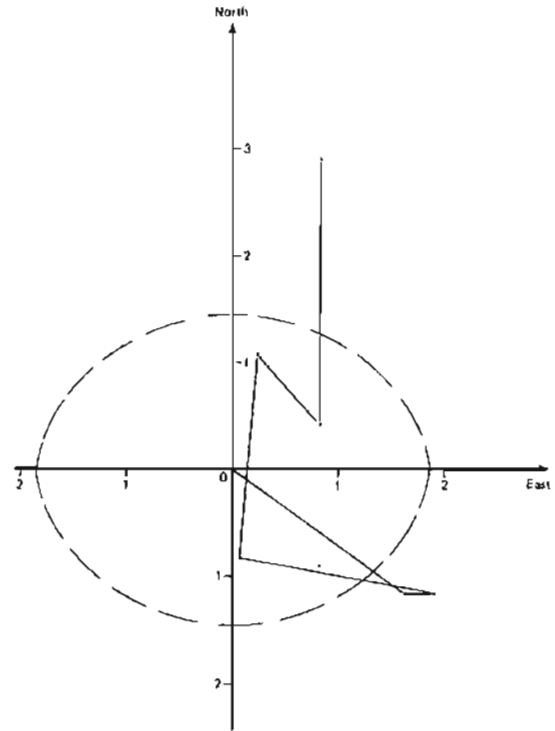

Figure 10. Apparent strain path of survey station 5.

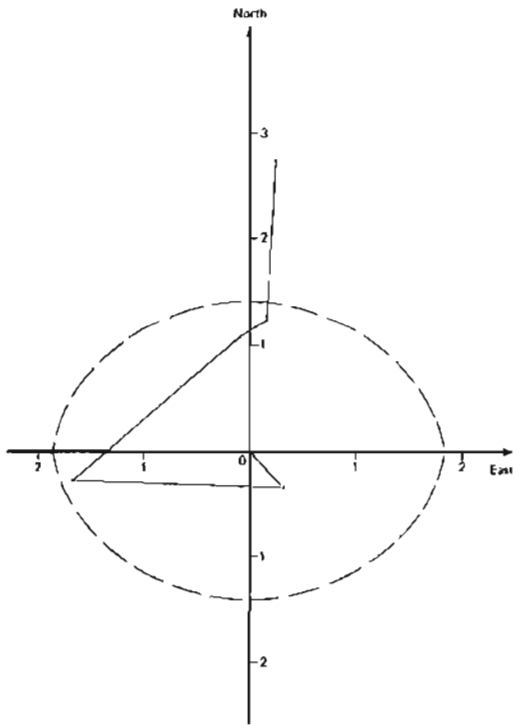

Figure 11. Apparent strain path of survey station 6.

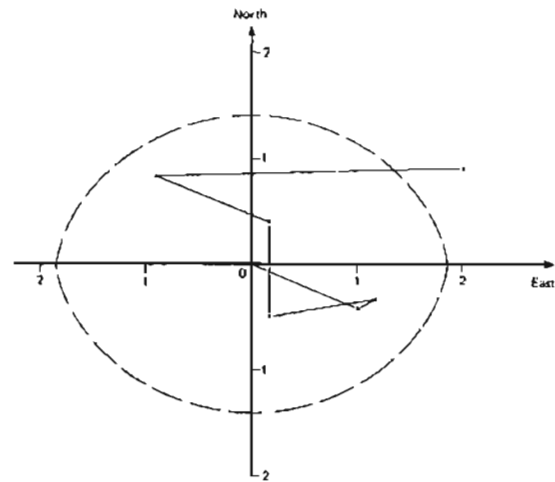

Figure 12. Apparent strain path of survey station 7.

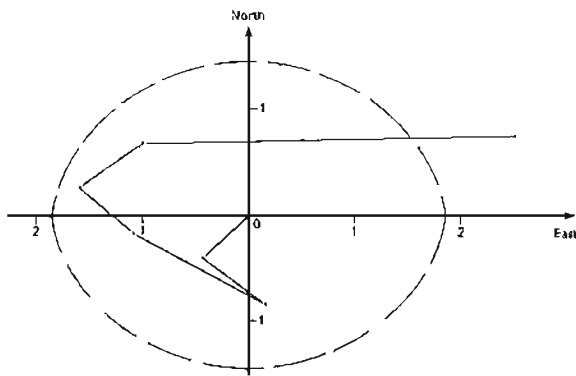

Figure 13. Apparent strain path of survey station 8.

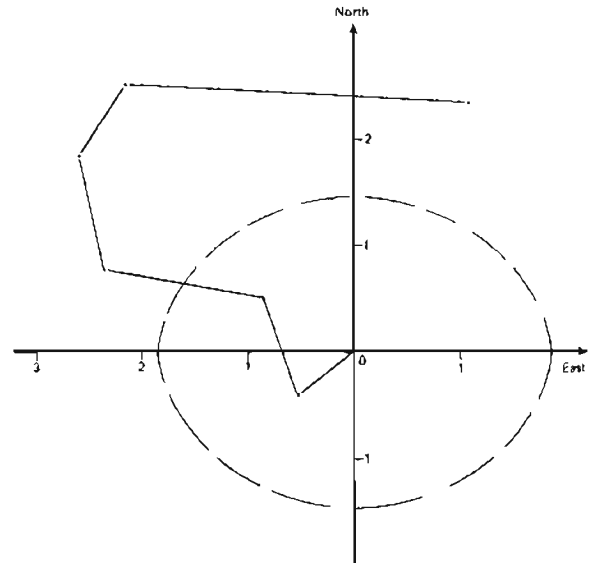

Figure 14. Apparent strain path of survey station 9.

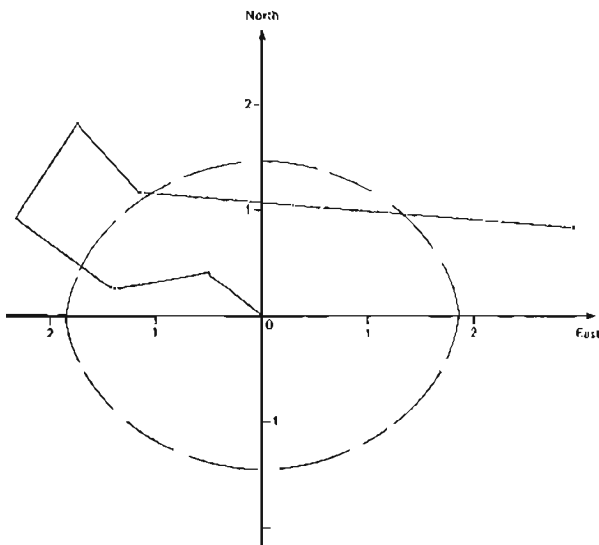

Figure 15. Apparent strain path of survey station 10.

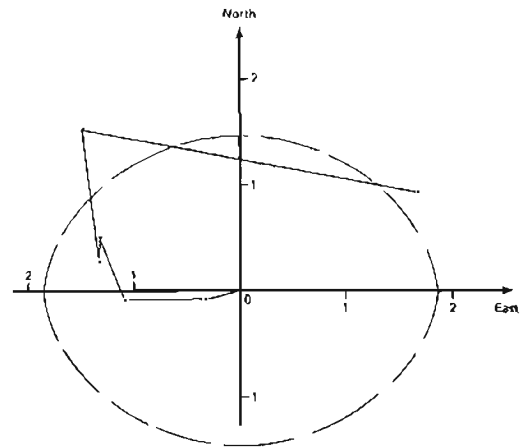

Figure 16. Apparent strain path of survey station 11.

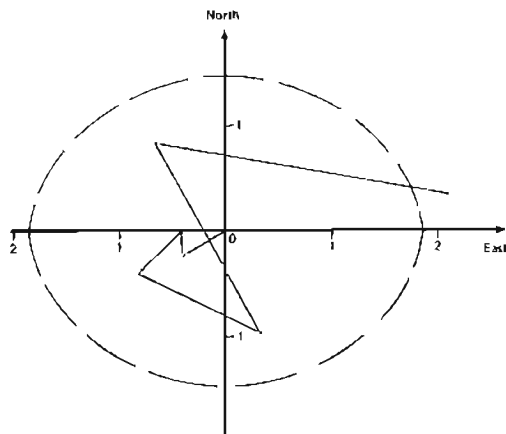

Figure 17. Apparent strain path of survey station 12.



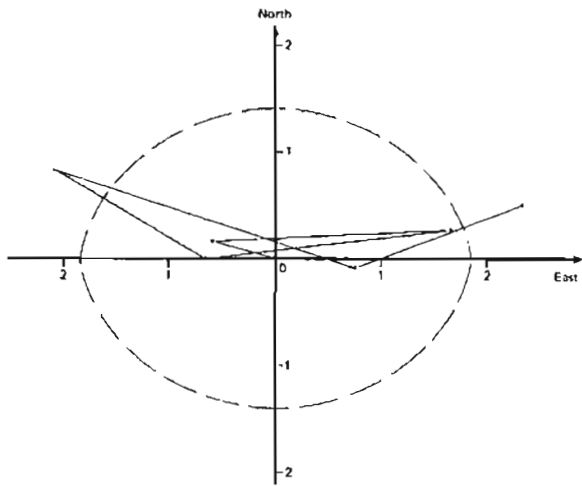

Figure 18. Apparent strain path of survey station 13.

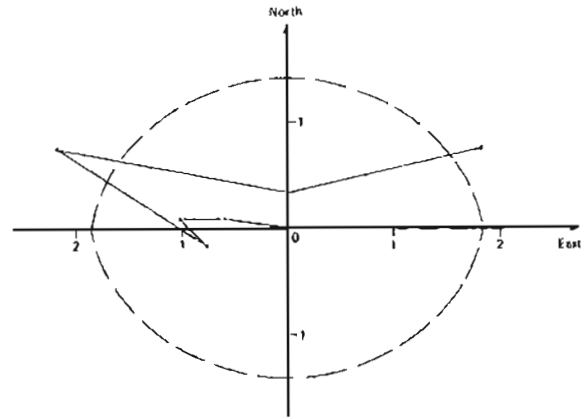

Figure 19. Apparent strain path of survey station 14.

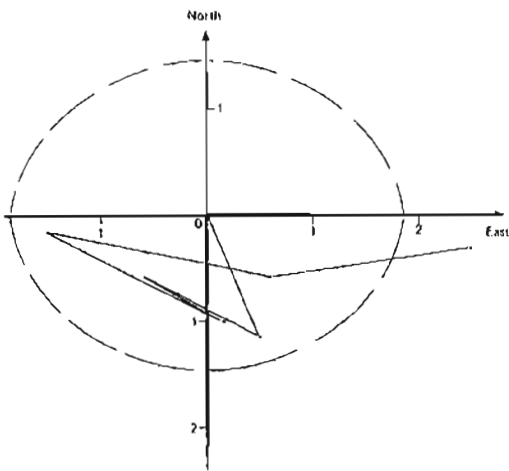

Figure 20. Apparent strain path of survey station 15.

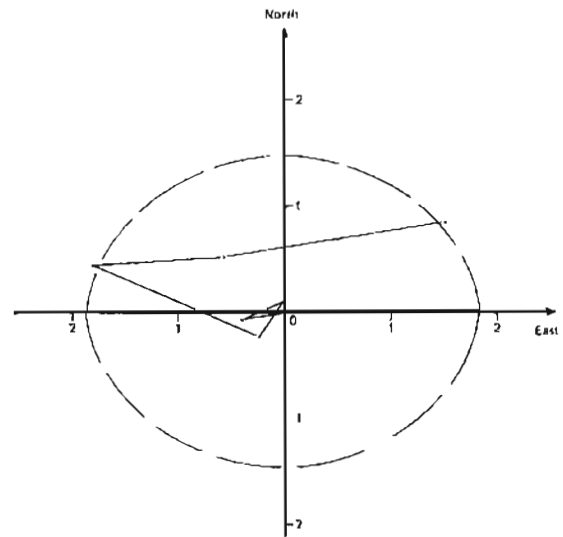

Figure 21. Apparent strain path of survey station 16.

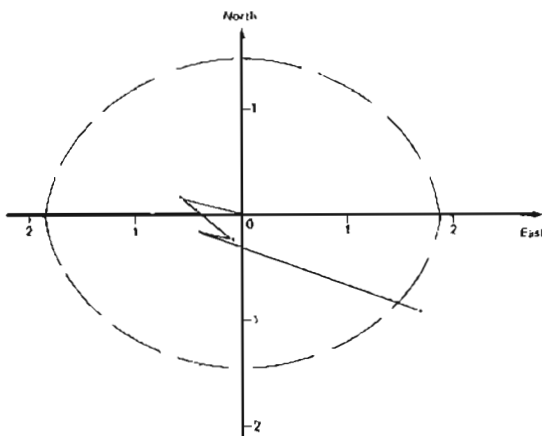

Figure 22. Apparent strain path of survey station 17.

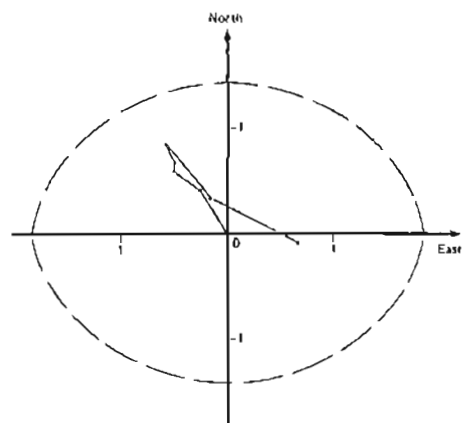

Figure 23. Apparent strain path of survey station 18.

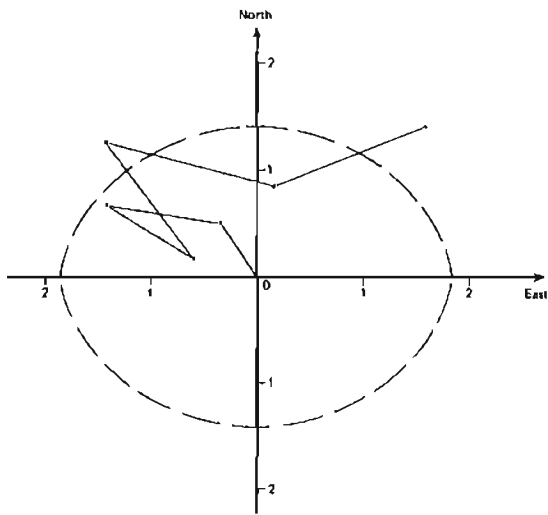

Figure 24. Apparent strain path of survey station 19.

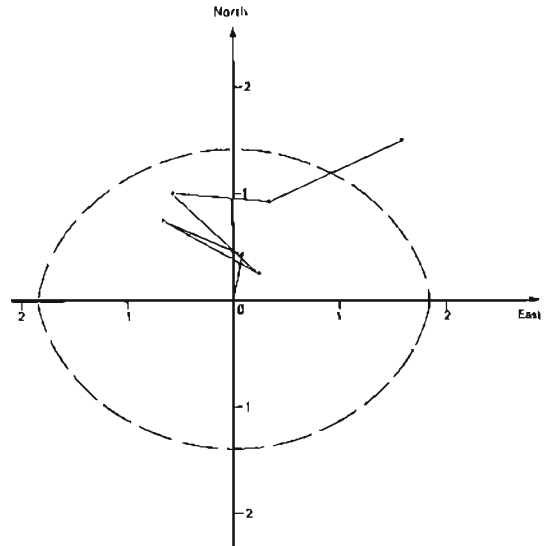

Figure 25. Apparent strain path of survey station 20.

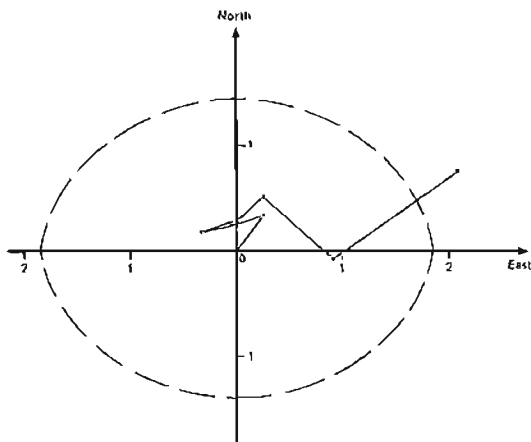

Figure 26. Apparent strain path of survey station 21.

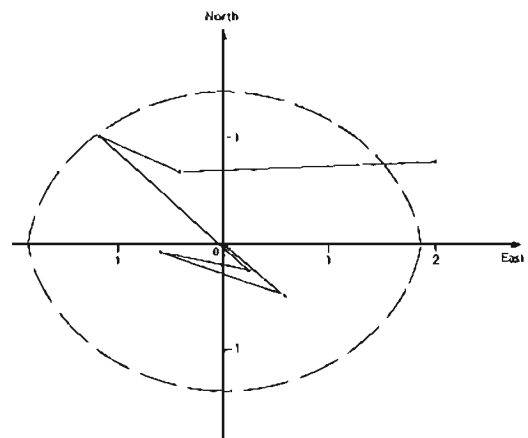

Figure 27. Apparent strain path of survey station 22.

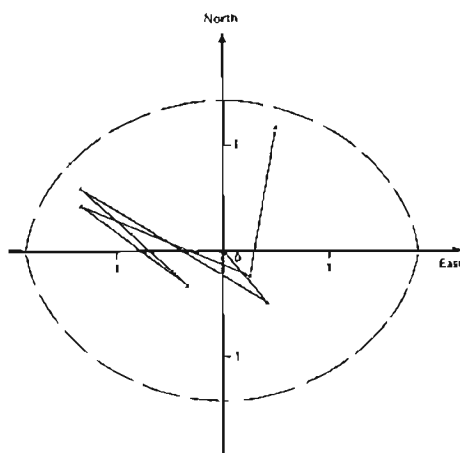

Figure 28. Apparent strain path of survey station 23.

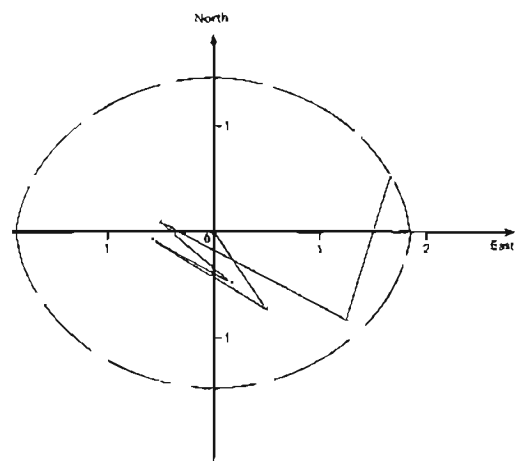

Figure 29. Apparent strain path of survey station 24.

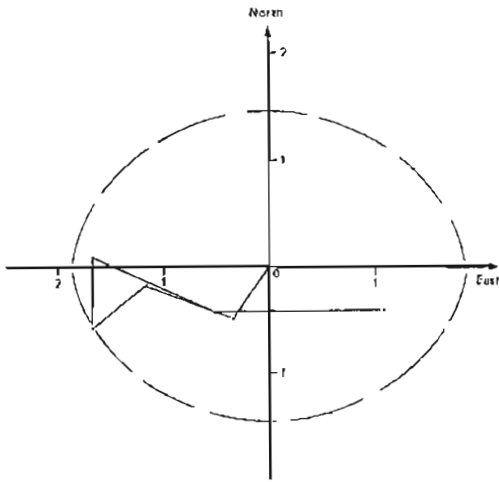

Figure 30. Apparent strain path of survey station 25.

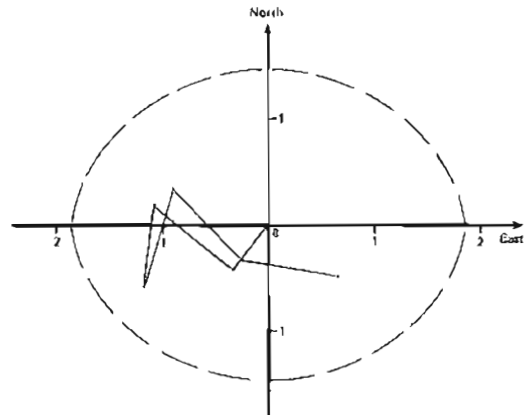

Figure 31. Apparent strain path of survey station 26.

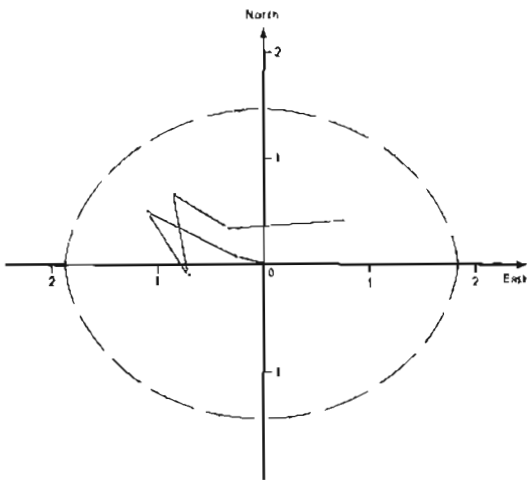

Figure 32. Apparent strain path of survey station 27.

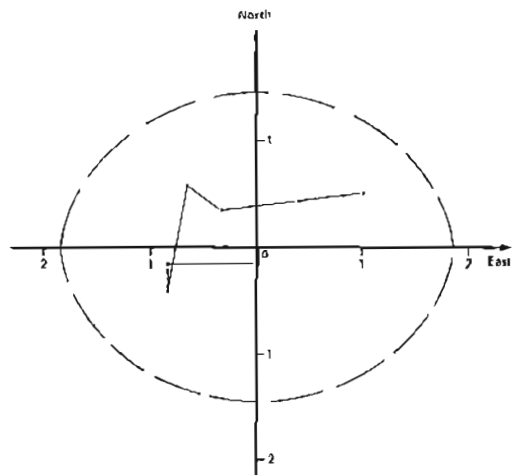

Figure 33. Apparent strain path of survey station 28.

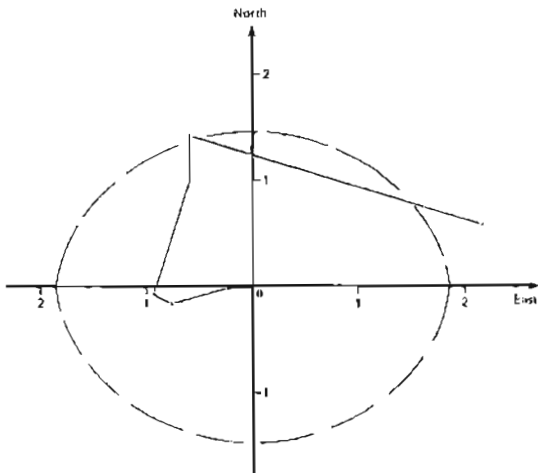

Figure 34. Apparent strain path of survey station 29.

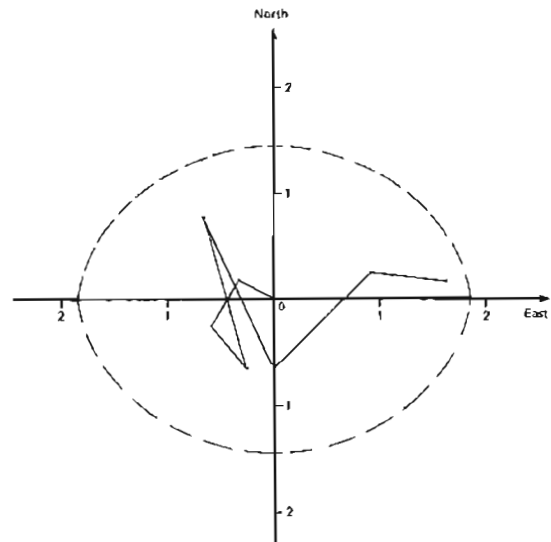

Figure 35. Apparent strain path of survey station 30.

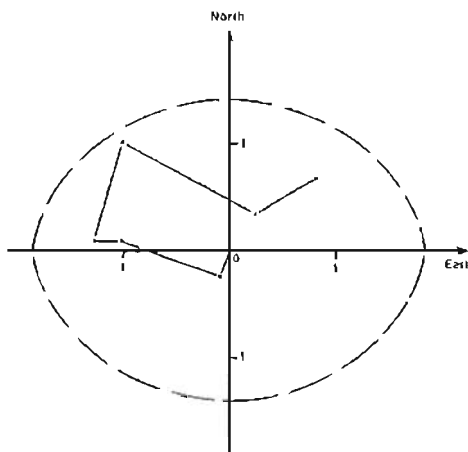

Figure 36. Apparent strain path of survey station 31.

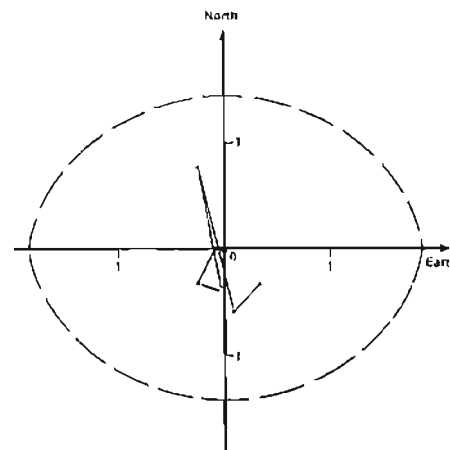

Figure 37. Apparent strain path of survey station 32.

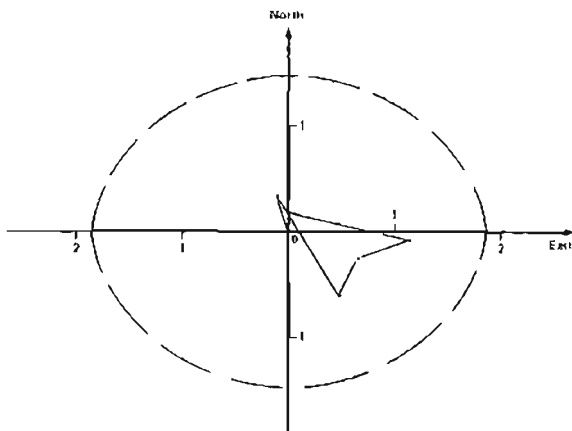

Figure 38. Apparent strain path of survey station 33.

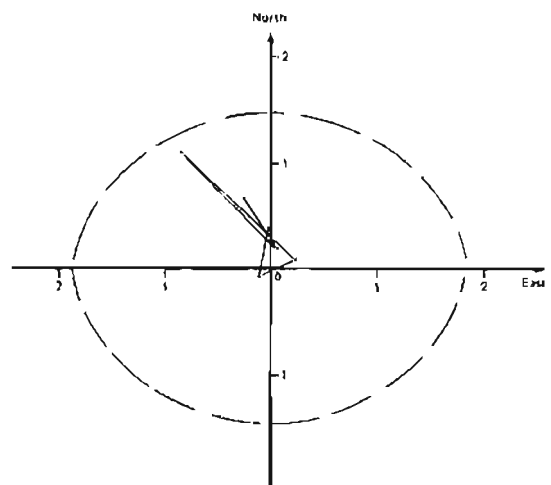

Figure 39. Apparent strain path of survey station 34.

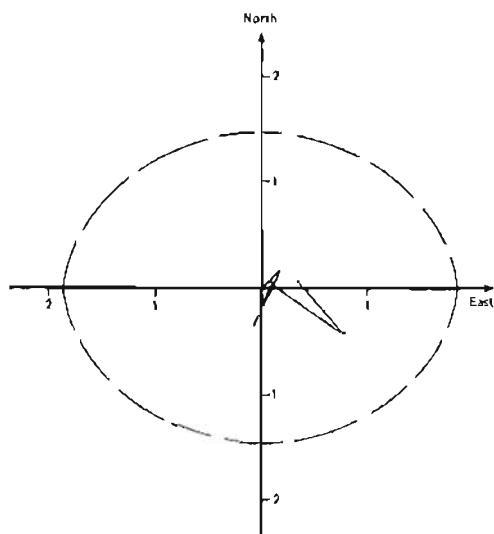

Figure 40. Apparent strain path of survey station 35.