

UNITED STATES DEPARTMENT OF THE INTERIOR
GEOLOGICAL SURVEY

HISTOGRAMS AND CORRELATION TABLE FOR
SELECTED ELEMENTS IN SAMPLES OF THE
ASH OF GROUND BIRCH LEAVES FROM THE
TANACROSS QUADRANGLE, ALASKA

by

G. C. Curtin, G. W. Day, and R. B. Tripp

Open-File Report 80-656

1980

CONTENTS

	Page
Discussion-----	1
References-----	3

FIGURES

Figure 1. Histogram showing iron, in percent, in samples of the ash of ground birch leaves from the Tanacross quadrangle, Alaska-----	4
2. Histogram showing magnesium, in percent, in samples of the ash of ground birch leaves from the Tanacross quadrangle, Alaska-----	5
3. Histogram showing titanium, in percent in samples of the ash of ground birch leaves from the Tanacross quadrangle, Alaska-----	6
4. Histogram showing manganese, in parts per million (ppm), in samples of the ash of ground birch leaves from the Tanacross quadrangle, Alaska-----	7
5. Histogram showing silver, in parts per million (ppm), in samples of the ash of ground birch leaves from the Tanacross quadrangle, Alaska-----	8
6. Histogram showing gold, in parts per million (ppm), in samples of the ash of ground birch leaves from the Tanacross quadrangle, Alaska-----	8
7. Histogram showing boron, in parts per million (ppm), in samples of the ash of ground birch leaves from the Tanacross quadrangle, Alaska-----	9

CONTENTS--Continued

FIGURES--Continued

	Page
Figure 8. Histogram showing barium, in parts per million (ppm), in samples of the ash of ground birch leaves from the Tanacross quadrangle, Alaska-----	10
9. Histogram showing cadmium, in parts per million (ppm), in samples of the ash of ground birch leaves from the Tanacross quadrangle, Alaska-----	11
10. Histogram showing cobalt, in parts per million (ppm), in samples of the ash of ground birch leaves from the Tanacross quadrangle, Alaska-----	12
11. Histogram showing chromium, in parts per million (ppm), in samples of the ash of ground birch leaves from the Tanacross quadrangle, Alaska-----	12
12. Histogram showing copper, in parts per million (ppm), in samples of the ash of ground birch leaves from the Tanacross quadrangle, Alaska-----	13
13. Histogram showing molybdenum, in parts per million (ppm), in samples of the ash of ground birch leaves from the Tanacross quadrangle, Alaska-----	14
14. Histogram showing nickel, in parts per million (ppm), in samples of the ash of ground birch leaves from the Tanacross quadrangle, Alaska-----	15
15. Histogram showing lead, in parts per million (ppm), in samples of the ash of ground birch leaves from the Tanacross quadrangle, Alaska-----	16

CONTENTS--Continued

FIGURES--Continued

	Page
Figure 16. Histogram showing strontium, in parts per million (ppm), in samples of the ash of ground birch leaves from the Tanacross quadrangle, Alaska-----	17
17. Histogram showing tin, in parts per million (ppm), in samples of the ash of ground birch leaves from the Tanacross quadrangle, Alaska-----	18
18. Histogram showing tungsten, in parts per million (ppm), in samples of the ash of ground birch leaves from the Tanacross quadrangle, Alaska-----	18
19. Histogram showing vanadium, in parts per million (ppm), in samples of the ash of ground birch leaves from the Tanacross quadrangle, Alaska-----	19
20. Histogram showing zinc, in parts per million (ppm), in samples of the ash of ground birch leaves from the Tanacross quadrangle, Alaska-----	20
21. Histogram showing zirconium, in parts per million (ppm), in samples of the ash of ground birch leaves from the Tanacross quadrangle, Alaska-----	21

CONTENTS--Continued

TABLE

	Page
Table 1. Simple linear correlation coefficients between logarithmic values of the element concentrations in the ash of 478 samples of ground birch leaves collected in the Tanacross quadrangle, Alaska-----	22

DISCUSSION

These histograms and correlation table show the distribution and abundance of, and correlations between, the populations of 21 elements in the ash of ground birch (Betula rotundifolia Sarg.) leaves collected throughout most of the Tanacross 1:250,000-scale quadrangle. The samples were collected during reconnaissance geochemical studies as part of the U.S. Geological Survey's Alaskan Mineral Resource Assessment Program. Related data for ground birch are presented in other reports (Day, Curtin, and Tripp, 1979 a,b,c), and background information on the mineral resource assessment of the Tanacross quadrangle is presented in a U.S. Geological Survey Circular (Foster and others, 1976).

COLLECTION, PREPARATION, AND ANALYSIS OF SAMPLES

Samples of ground birch leaves were collected along streams near sites where stream sediments, heavy-mineral concentrates, and other samples were obtained.

Several branches from each of 2 or 3 bushes were sampled at each site to produce a composite sample. The present years' growth of leaves and twigs were pruned from the branches, placed in cloth bags and allowed to dry. The leaves were separated from the twigs and finely chopped in a blender. This composition was then ashed in a furnace at a peak temperature of approximately 500°C for 24 hours.

The ashed material was analyzed by an optical emission spectrographic method for plant materials (Mosier, 1972) for 29 elements including the 21 elements whose distributions are shown in the histograms. Elements not present in measurable amounts are: arsenic, beryllium, bismuth, lanthanum, niobium, antimony, scandium, and yttrium.

The results were entered into the computerized Rock Analysis Storage System (RASS) of the U.S. Geological Survey (VanTrump and Miesch, 1977) and data sets were analyzed by statistical programs in the U.S. Geological Survey's STATPAC system to produce the tabular statistics for the histograms and the correlation table. Arithmetic means, standard deviations, geometric means, and geometric deviations are shown for those element distributions in which there are less than 5 percent censored values. The correlation coefficients in the correlation table (table 1) that are in bold type are statistically significant at the 5 percent error level.

REFERENCES

- Day, G. W., Curtin, G. C., and Tripp, R. B., 1979a, Geochemical maps showing the distribution and abundance of lead, zinc, and cadmium in the ash of black spruce needles and ground birch leaves from the Tanacross quadrangle, Alaska: U.S. Geological Survey Open-file Report 79-1319.
- 1979b, Geochemical maps showing the distribution and abundance of copper and molybdenum in the ash of black spruce needles and ground birch leaves from the Tanacross quadrangle, Alaska: U.S. Geological Survey Open-file Report 79-1320.
- 1979c, Spectrographic analyses of the ash of ground birch leaves and black spruce needles from the Tanacross quadrangle, Alaska: U.S. Geological Survey Open-file Report 79-1355.
- Foster, H. L., Albert, N. R. D., Barnes, D. R., Curtin, G. C., Griscom, Andrew, Singer, D. A., and Smith, J. G., 1976, The Alaskan Mineral Resource Assessment Program: Background information to accompany folio of geologic and mineral resource maps of the Tanacross quadrangle, Alaska: U.S. Geological Survey Circular 734, 23p.
- Mosier, E. L., 1972, A method for semiquantitative spectrographic analysis of plant ash for use in biogeochemical and environmental studies: Applied Spectroscopy, v. 26, no.6, p. 636-640.
- VanTrump, George, Jr., and Miesch, A. T., 1977, the U.S. Geological Survey RASS-STATPAC system for management and statistical reduction of geochemical data: Computers and Geosciences. v. 3, 0. 475-488.

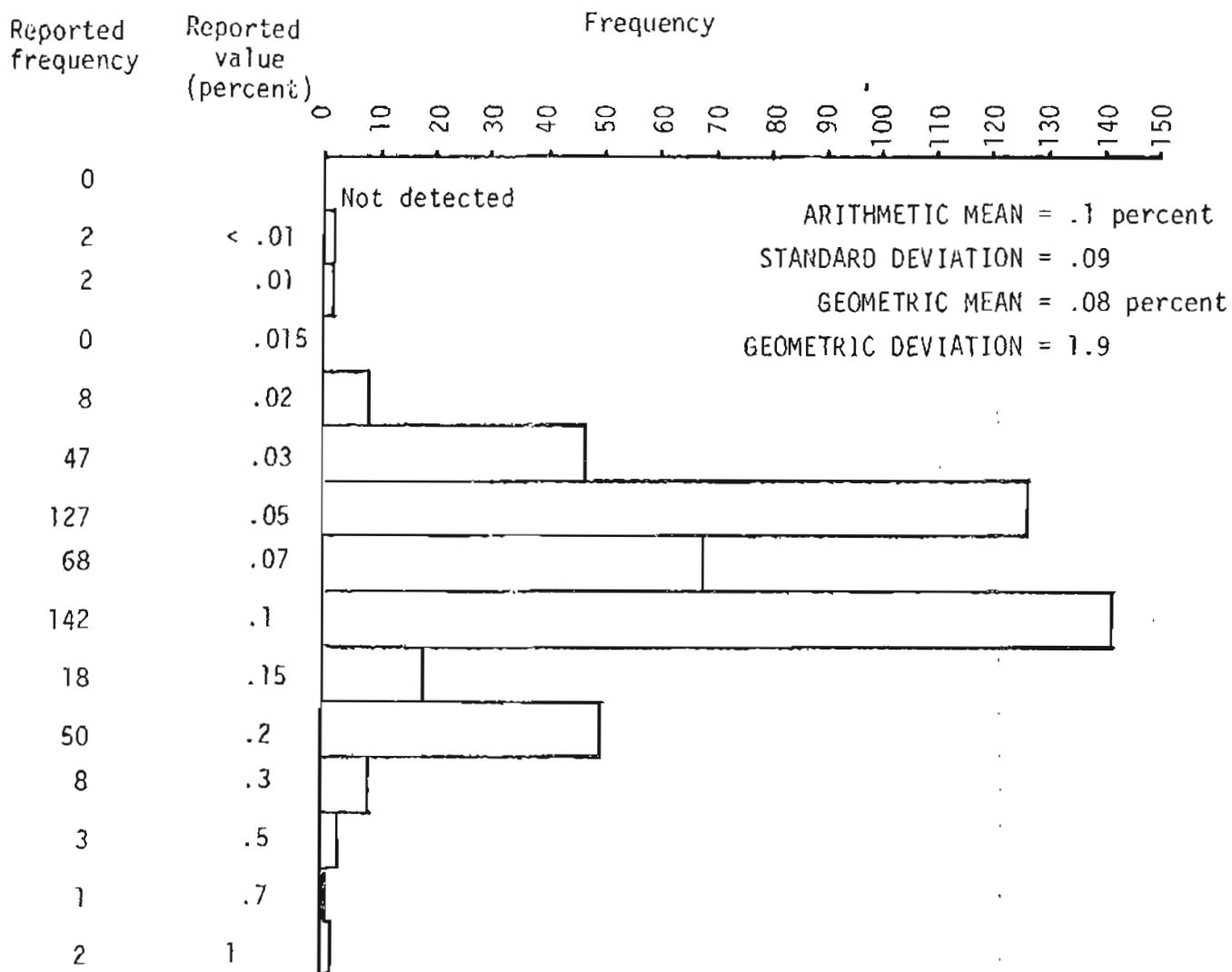

Figure 1.--Histogram showing iron, in percent, in samples of the ash of ground birch leaves from the Tanacross quadrangle, Alaska.

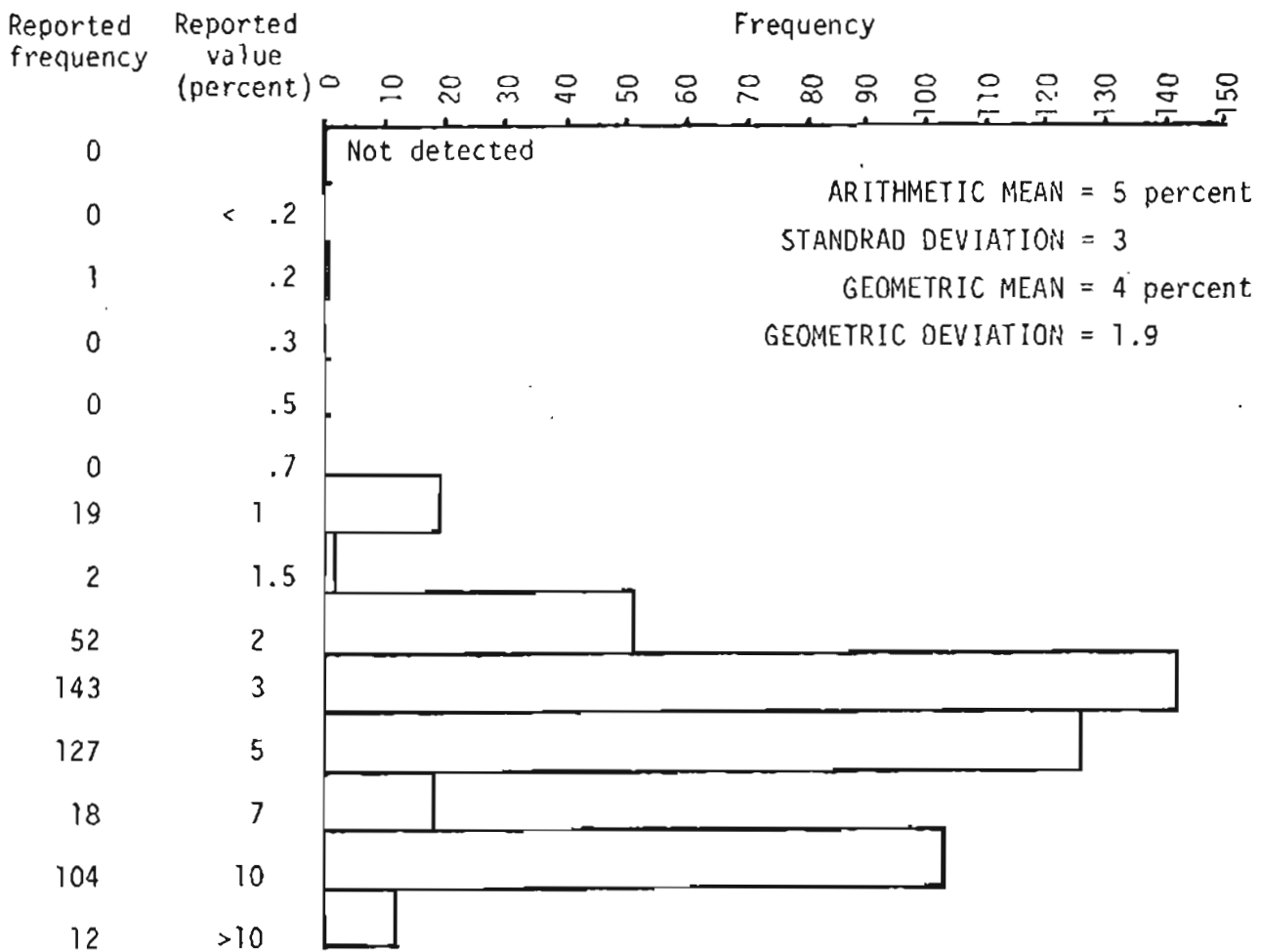

Figure 2.--Histogram showing magnesium, in percent, in samples of the ash of ground birch leaves from the Tanacross quadrangle, Alaska.

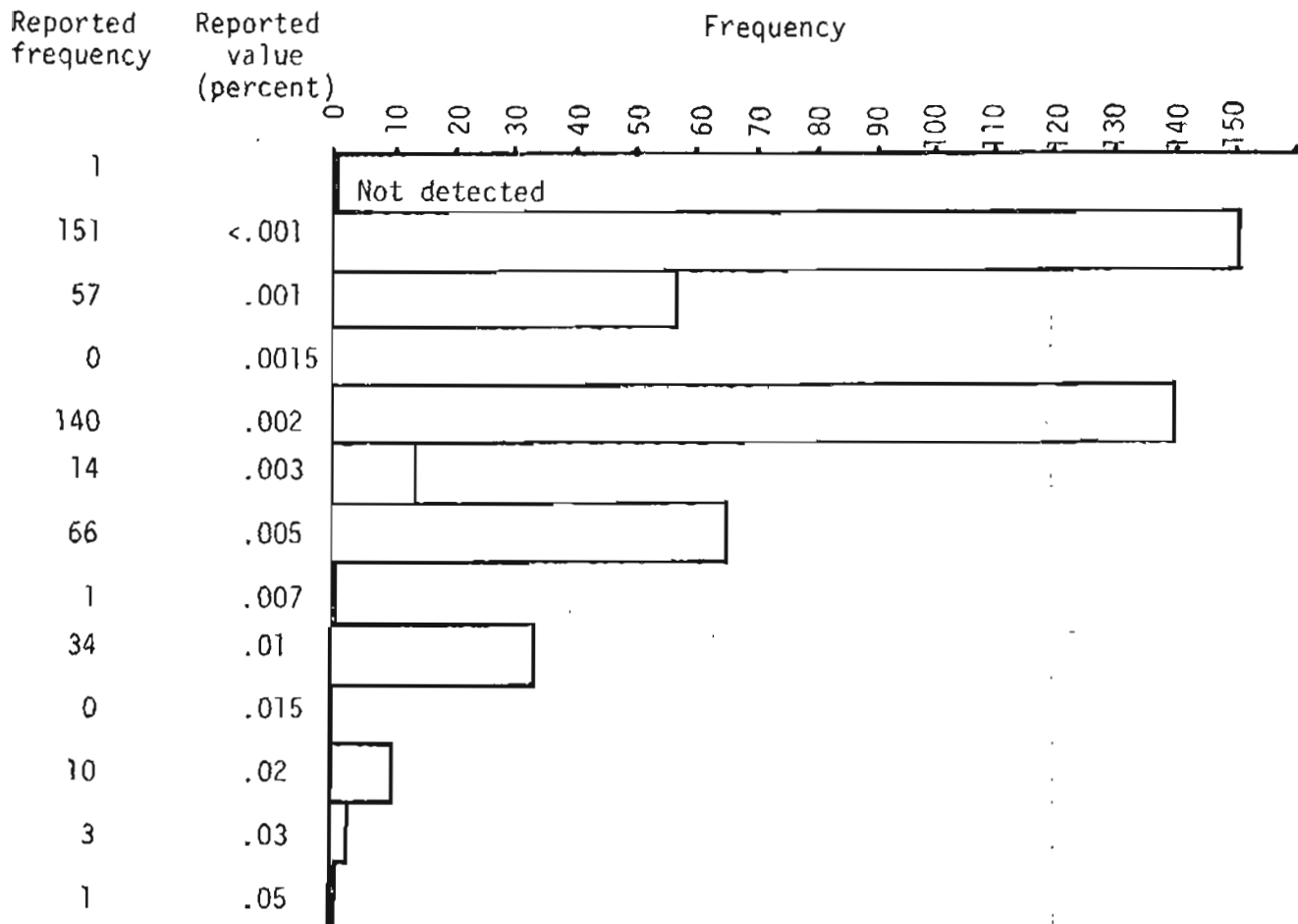

Figure 3.--Histogram showing titanium, in percent in samples of the ash of ground birch leaves from the Tanacross quadrangle, Alaska.

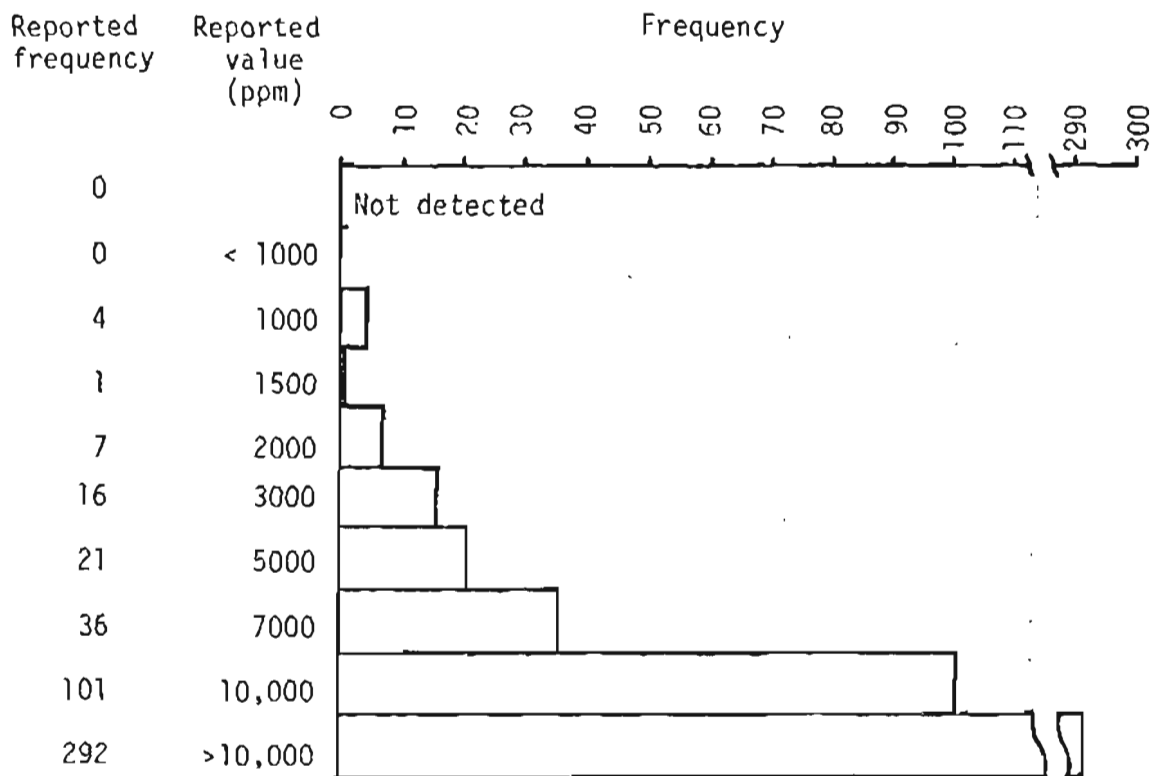

Figure 4.--Histogram showing manganese, in parts per million (ppm), in samples of the ash of ground birch leaves from the Tanacross quadrangle, Alaska.

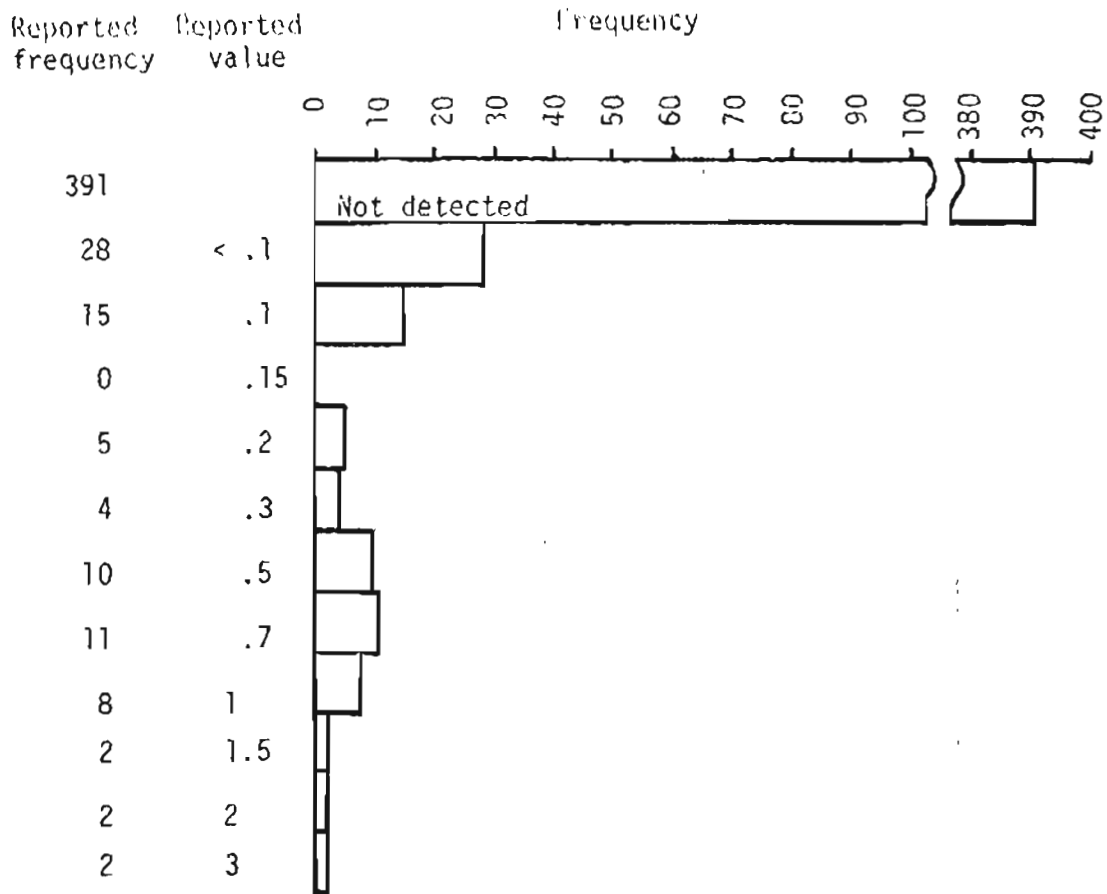

Figure 5.--Histogram showing silver, in parts per million (ppm), in samples of the ash of ground birch leaves from the Tanacross quadrangle, Alaska. 4.

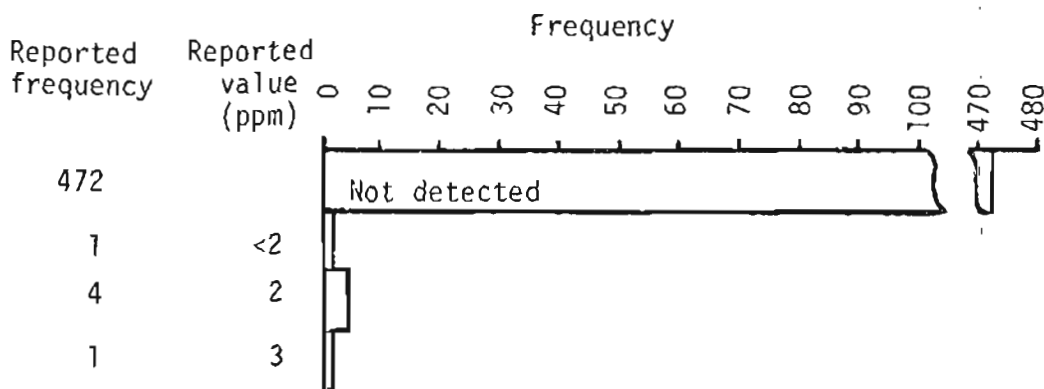

Figure 6.--Histogram showing gold, in parts per million (ppm), in samples of the ash of ground birch leaves from the Tanacross quadrangle, Alaska.

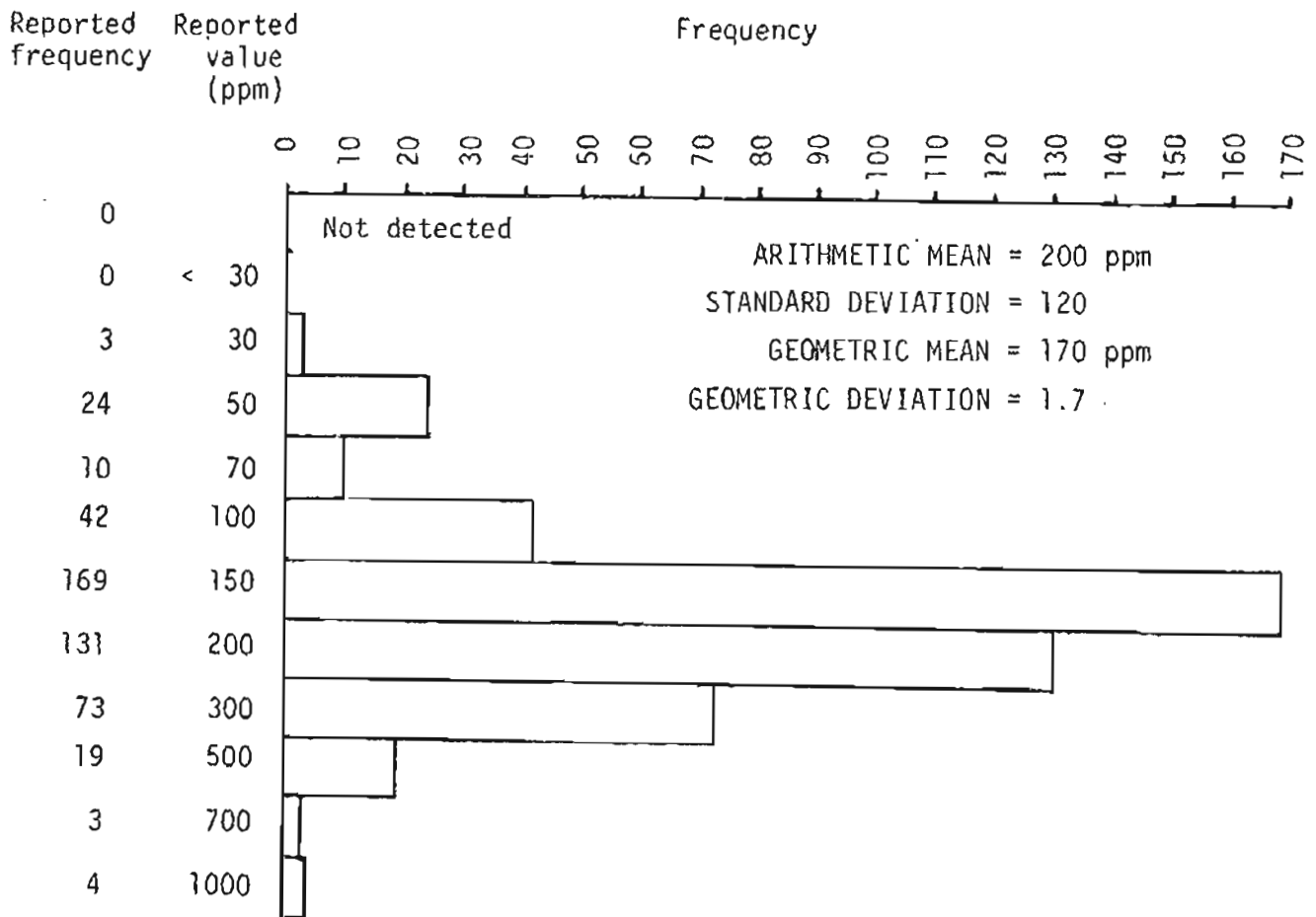

Figure 7.--Histogram showing boron, in parts per million (ppm), in samples of the ash of ground birch leaves from the Tanacross quadrangle, Alaska.

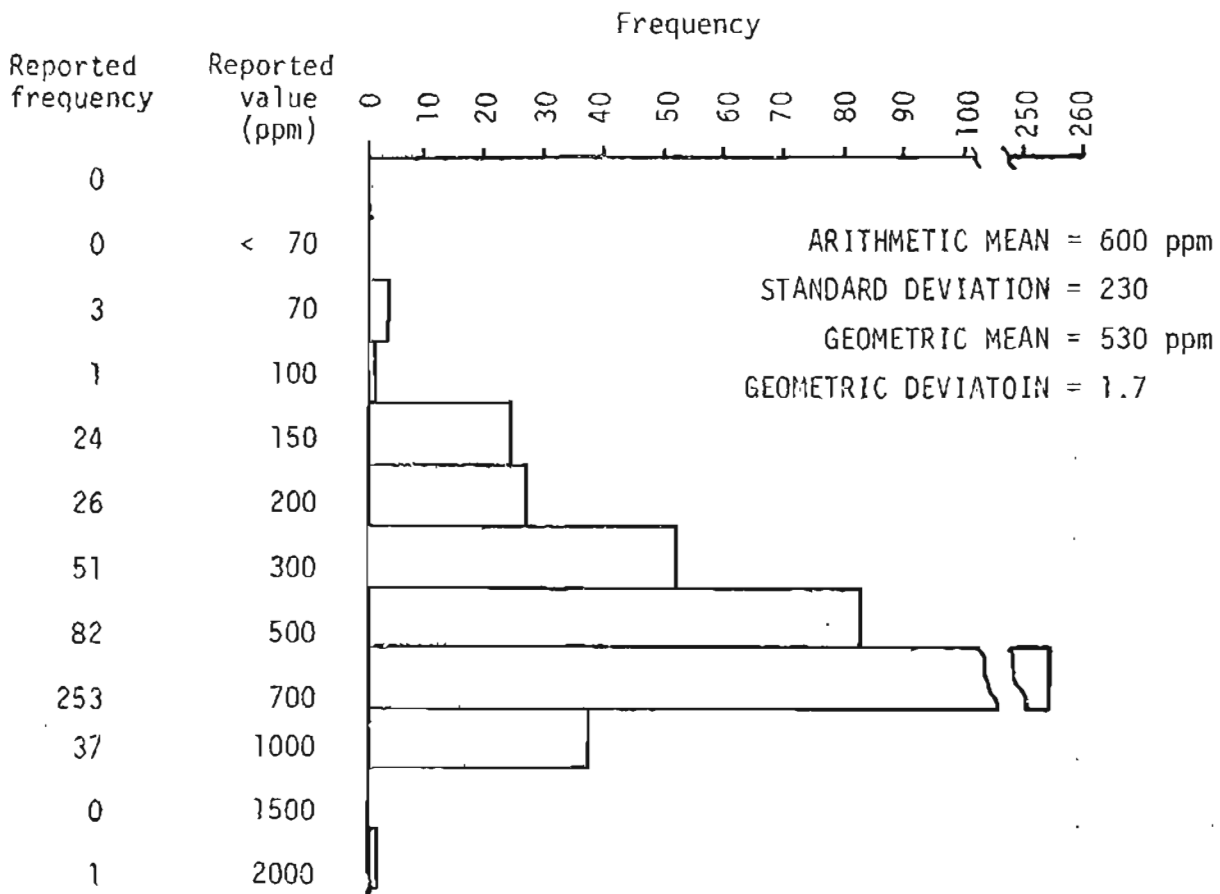

Figure 8.--Histogram showing barium, in parts per million (ppm), in samples of the ash of ground birch leaves from the Tanacross quadrangle, Alaska.

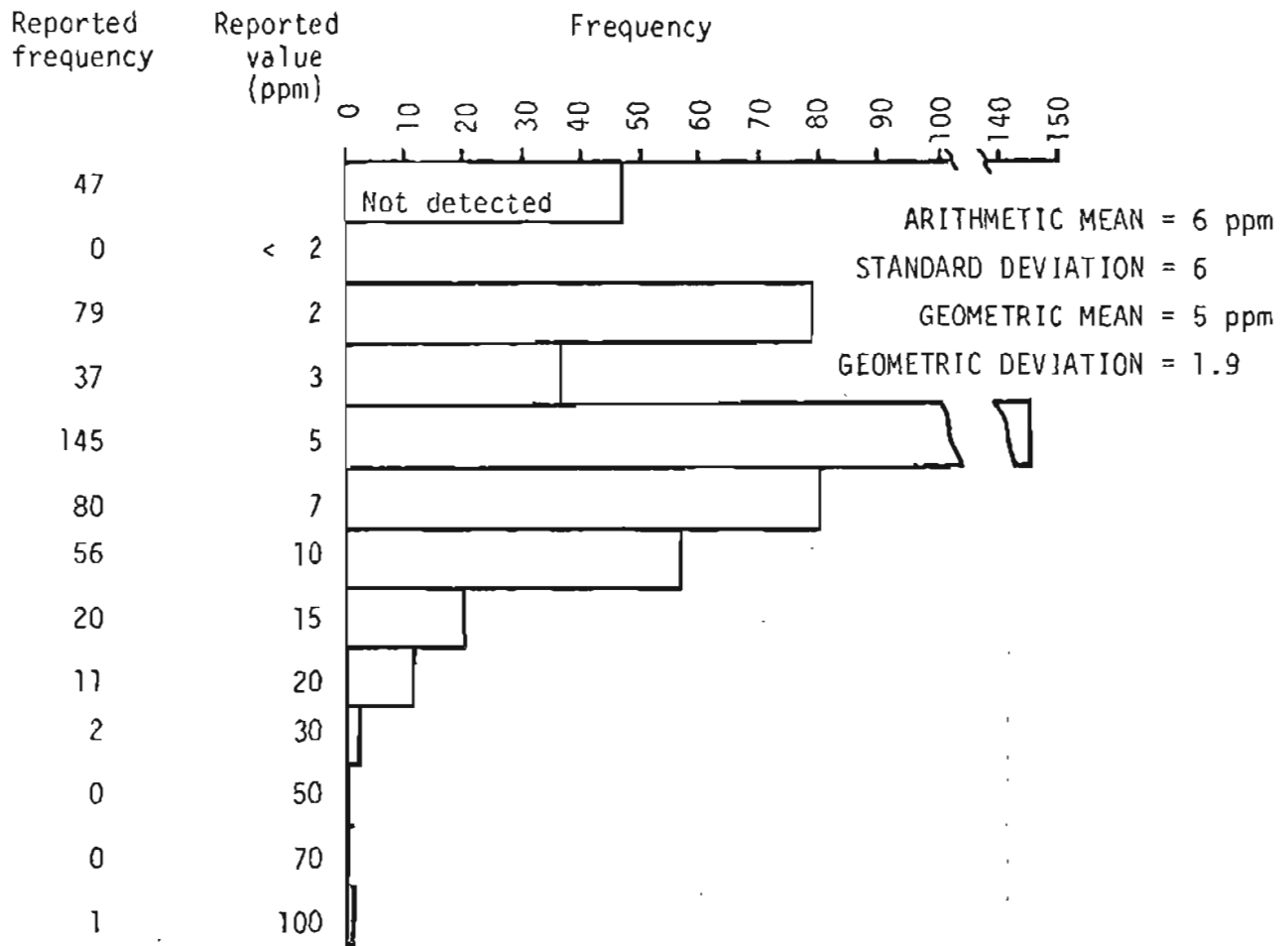

Figure 9.--Histogram showing cadmium, in parts per million (ppm), in samples of the ash of ground birch leaves from the Tanacross quadrangle, Alaska.

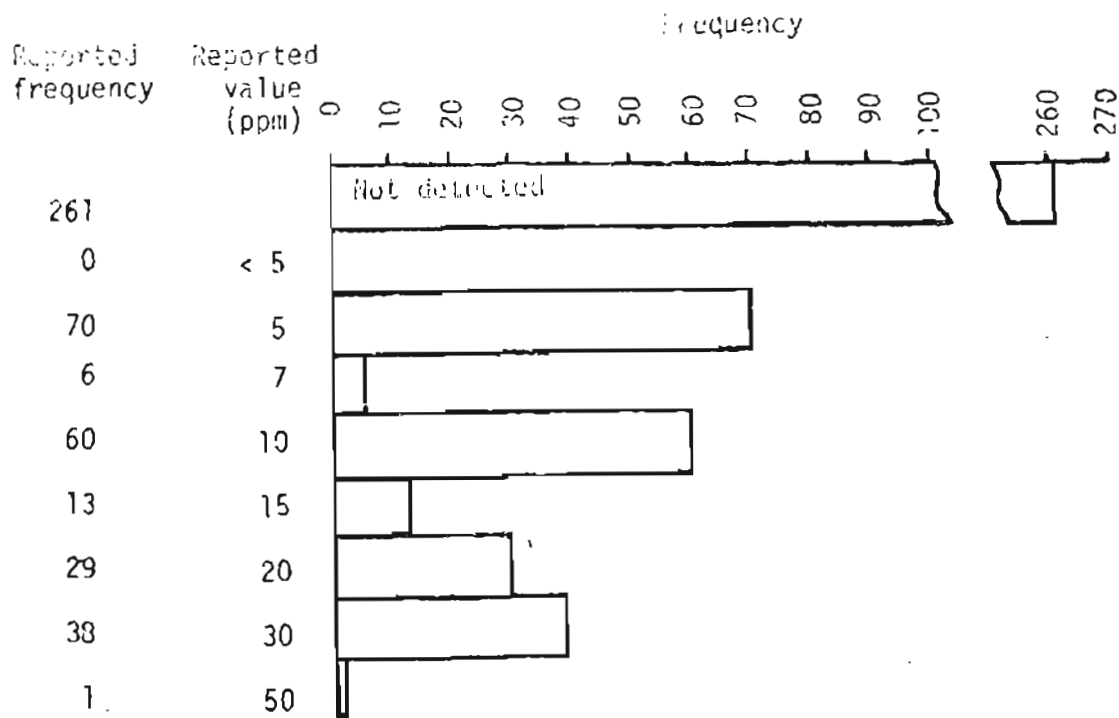

Figure 10.--Histogram showing cobalt, in parts per million (ppm), in samples of the ash of ground birch leaves from the Tanacross quadrangle, Alaska.

C r 11 b

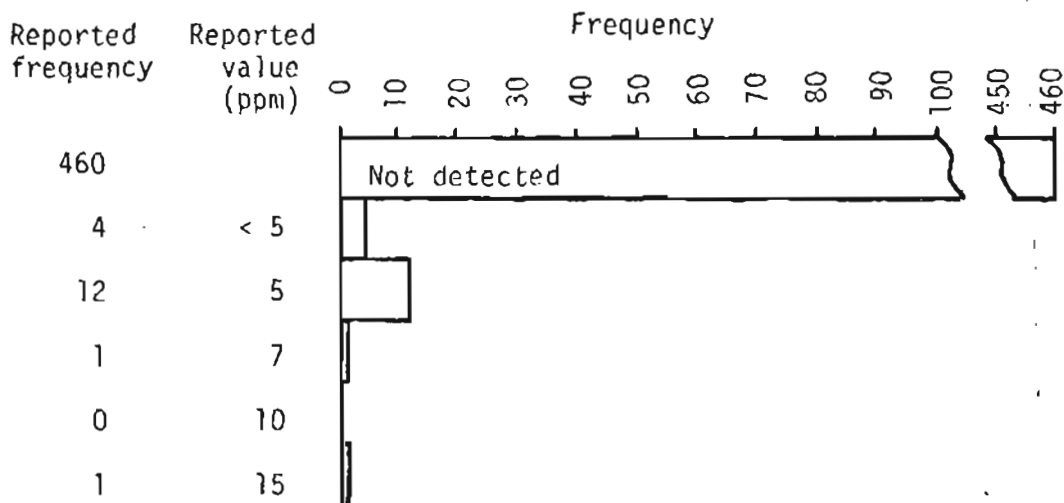

Figure 11.--Histogram showing chromium, in parts per million (ppm), in samples of the ash of ground birch leaves from the Tanacross quadrangle, Alaska.

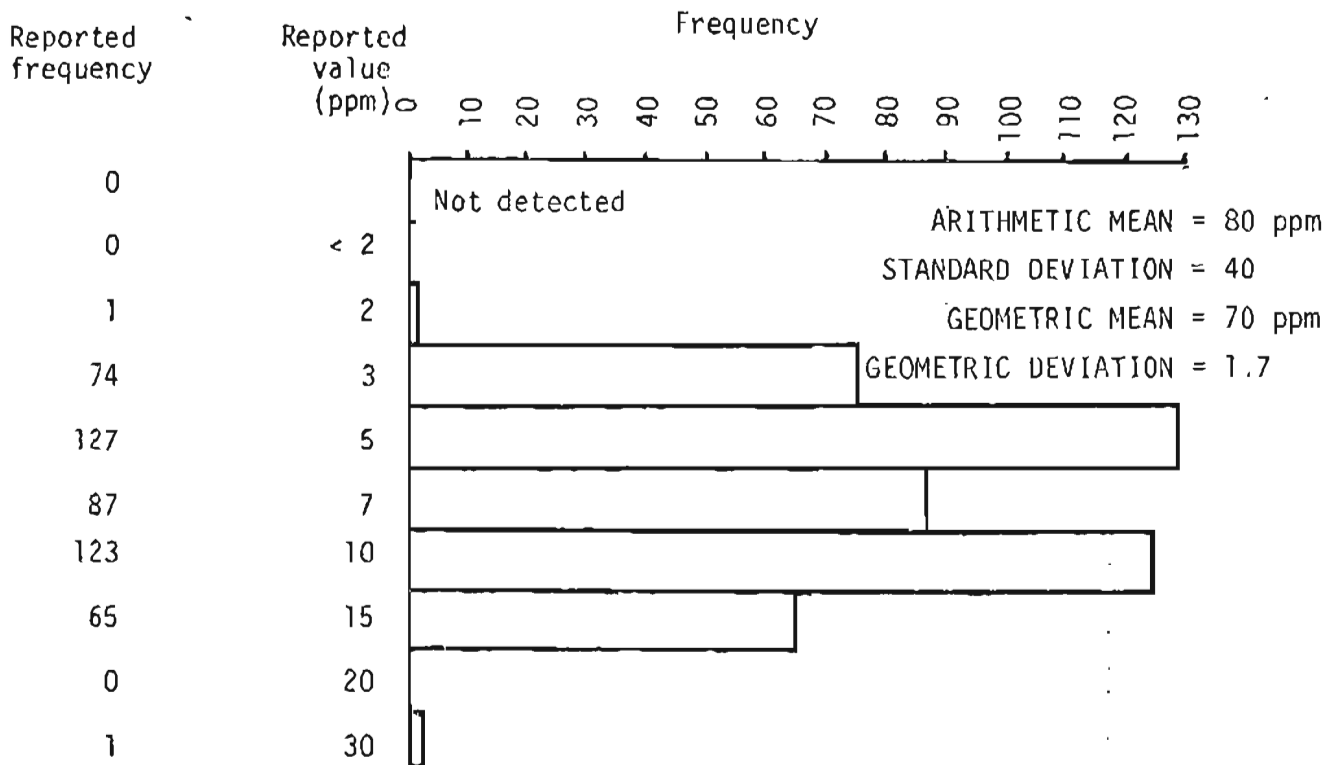

Figure 12.--Histogram showing copper, in parts per million (ppm), in samples of the ash of ground birch leaves from the Tanacross quadrangle, Alaska.

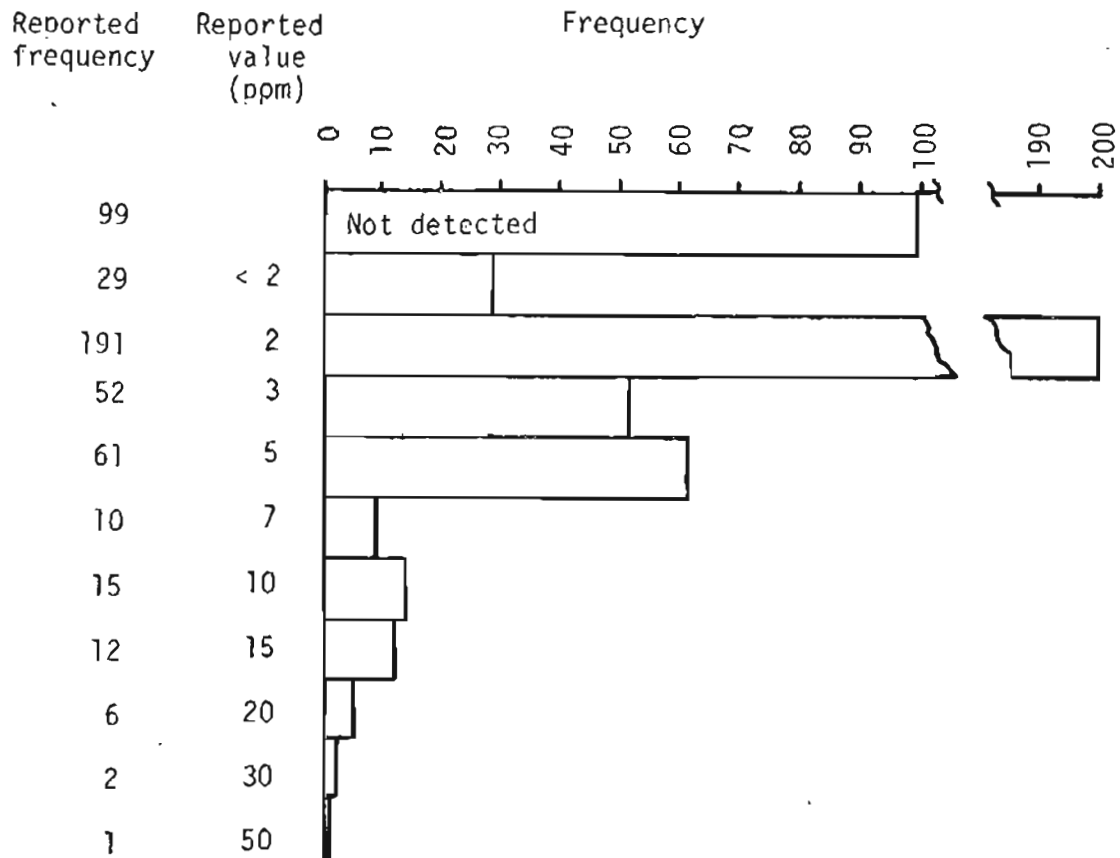

Figure 13.--Histogram showing molybdenum, in parts per million (ppm), in samples of the ash of ground birch leaves from the Tanacross quadrangle, Alaska.

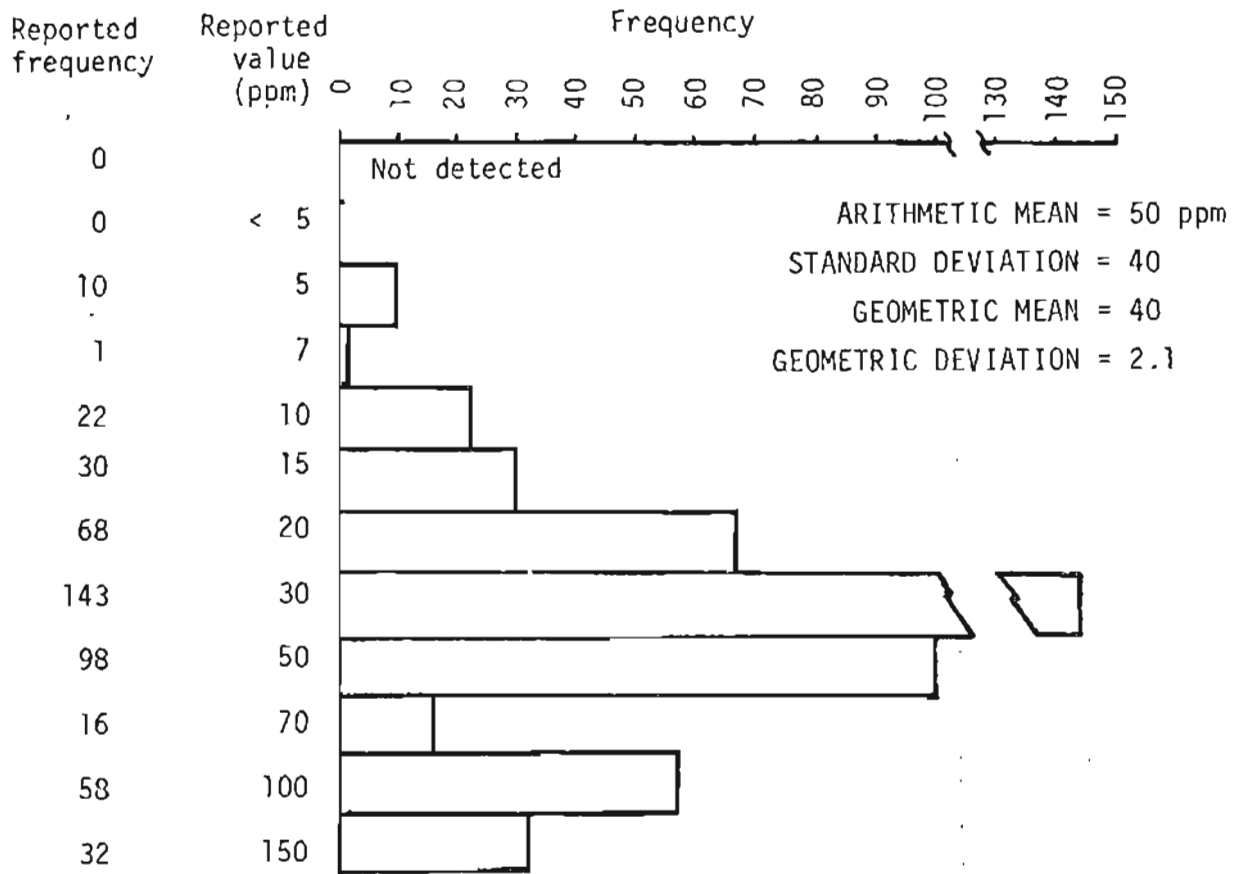

Figure 14.--Histogram showing nickel, in parts per million (ppm), in samples of the ash of ground birch leaves from the Tanacross quadrangle, Alaska.

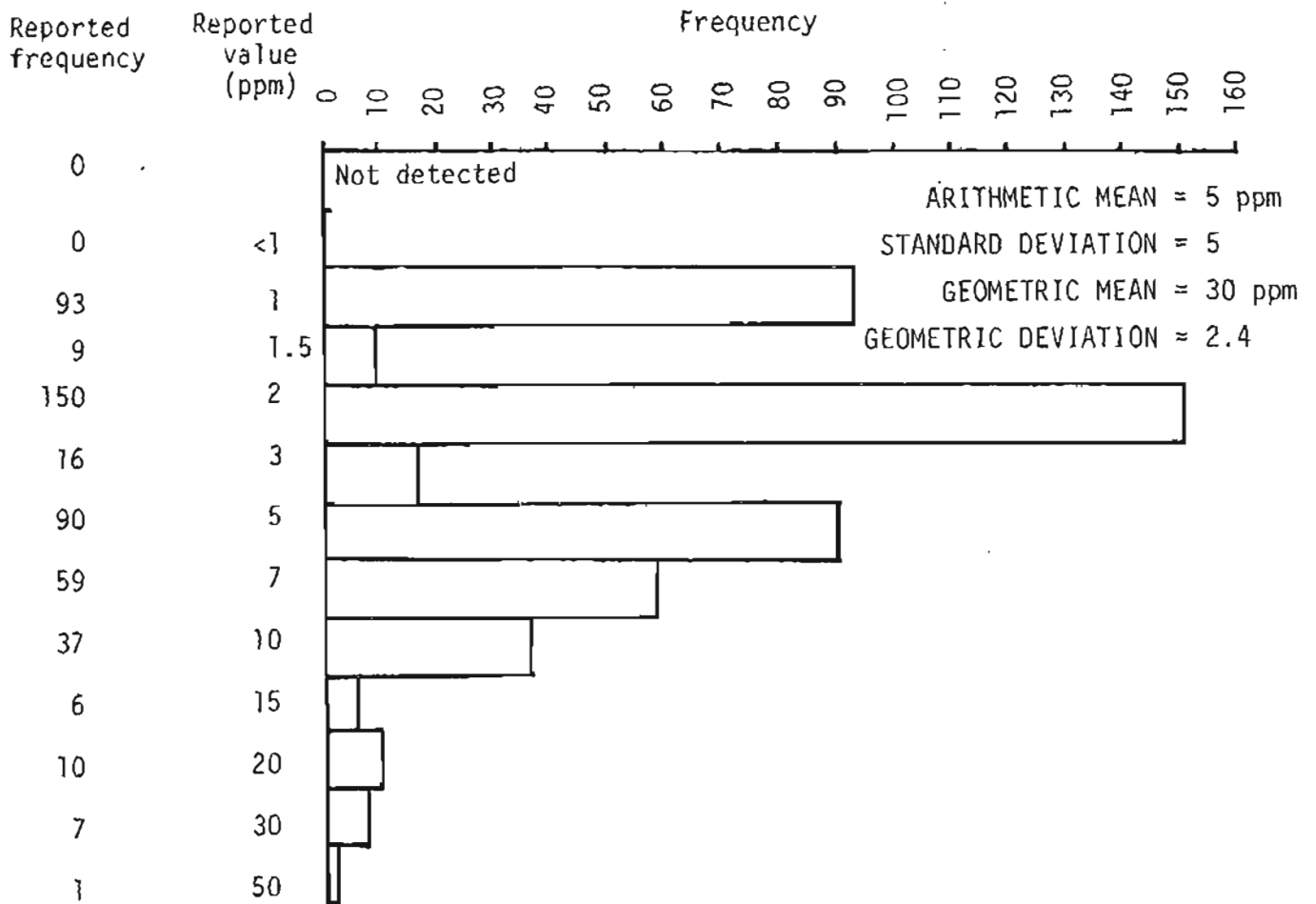

Figure 15.--Histogram showing lead, in parts per million (ppm), in samples of the ash of ground birch leaves from the Tanacross quadrangle, Alaska.

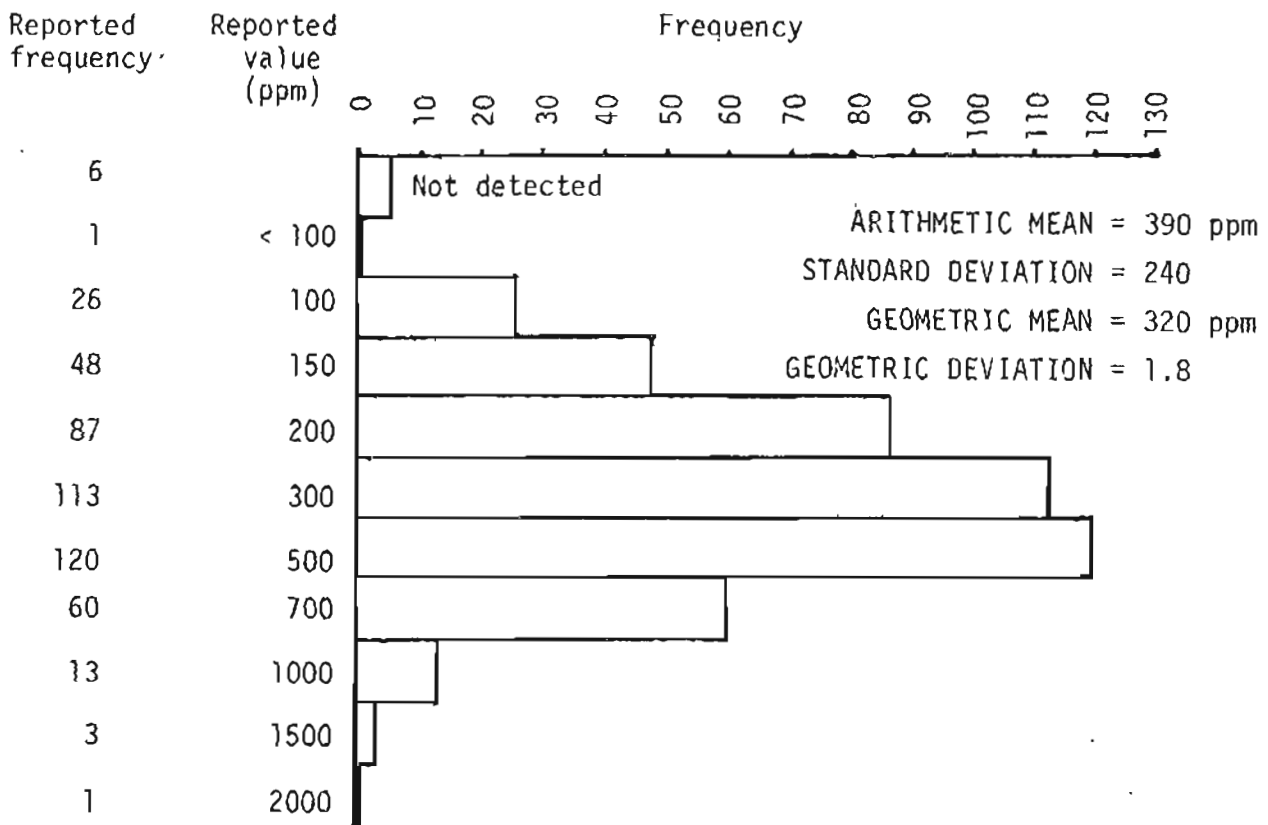

Figure 16.--Histogram showing strontium, in parts per million (ppm), in samples of the ash of ground birch leaves from the Tanacross quadrangle, Alaska.

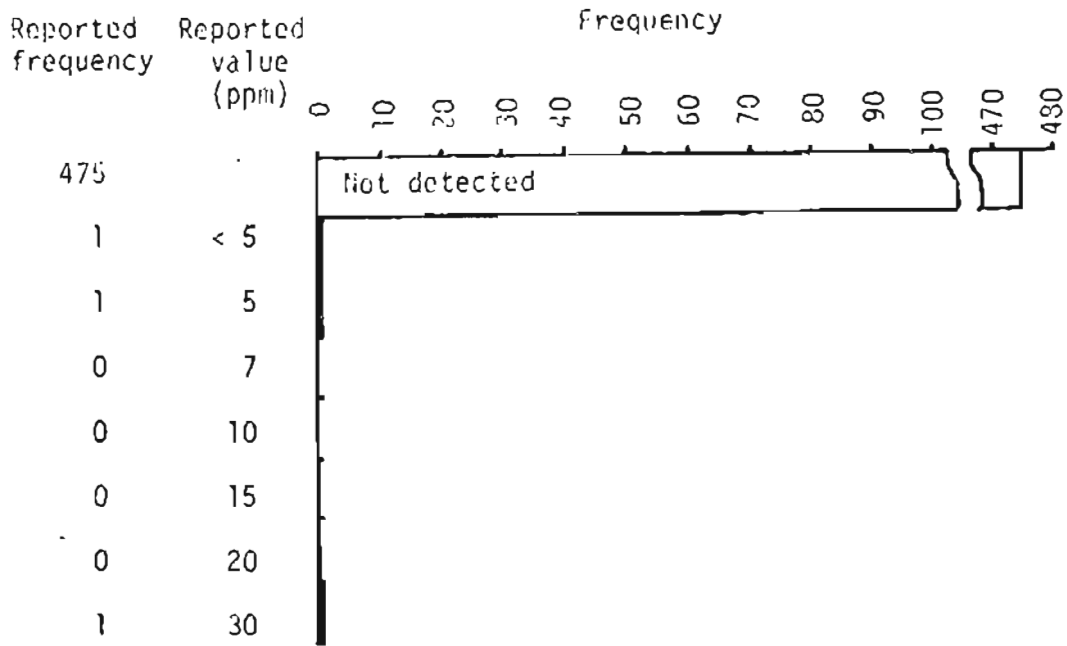

Figure 17.--Histogram showing tin, in parts per million (ppm), in samples of the ash of ground birch leaves from the Tanacross quadrangle, Alaska.

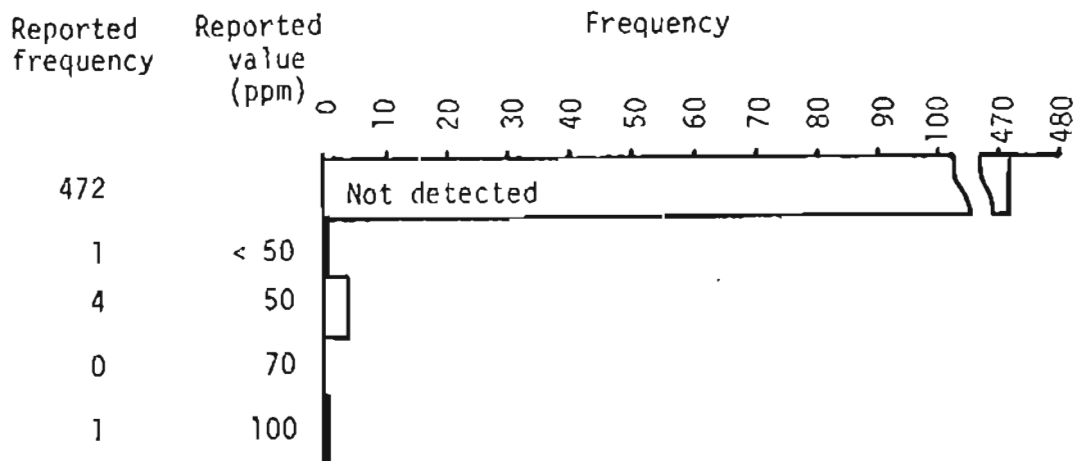

Figure 18.--Histogram showing tungsten, in parts per million (ppm), in samples of the ash of ground birch leaves from the Tanacross quadrangle, Alaska.

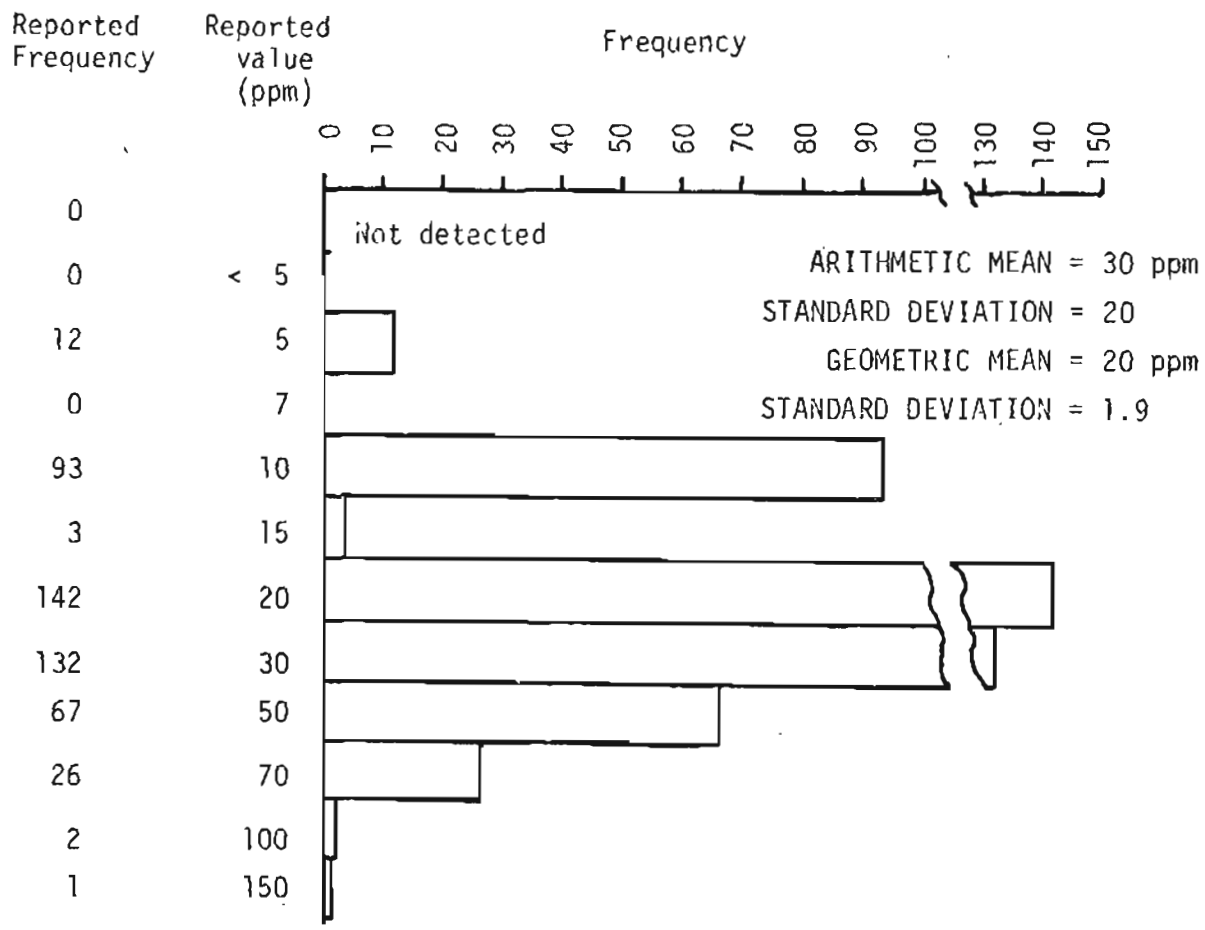

Figure 19.--Histogram showing vanadium, in parts per million (ppm), in samples of the ash of ground birch leaves from the Tanacross quadrangle, Alaska.

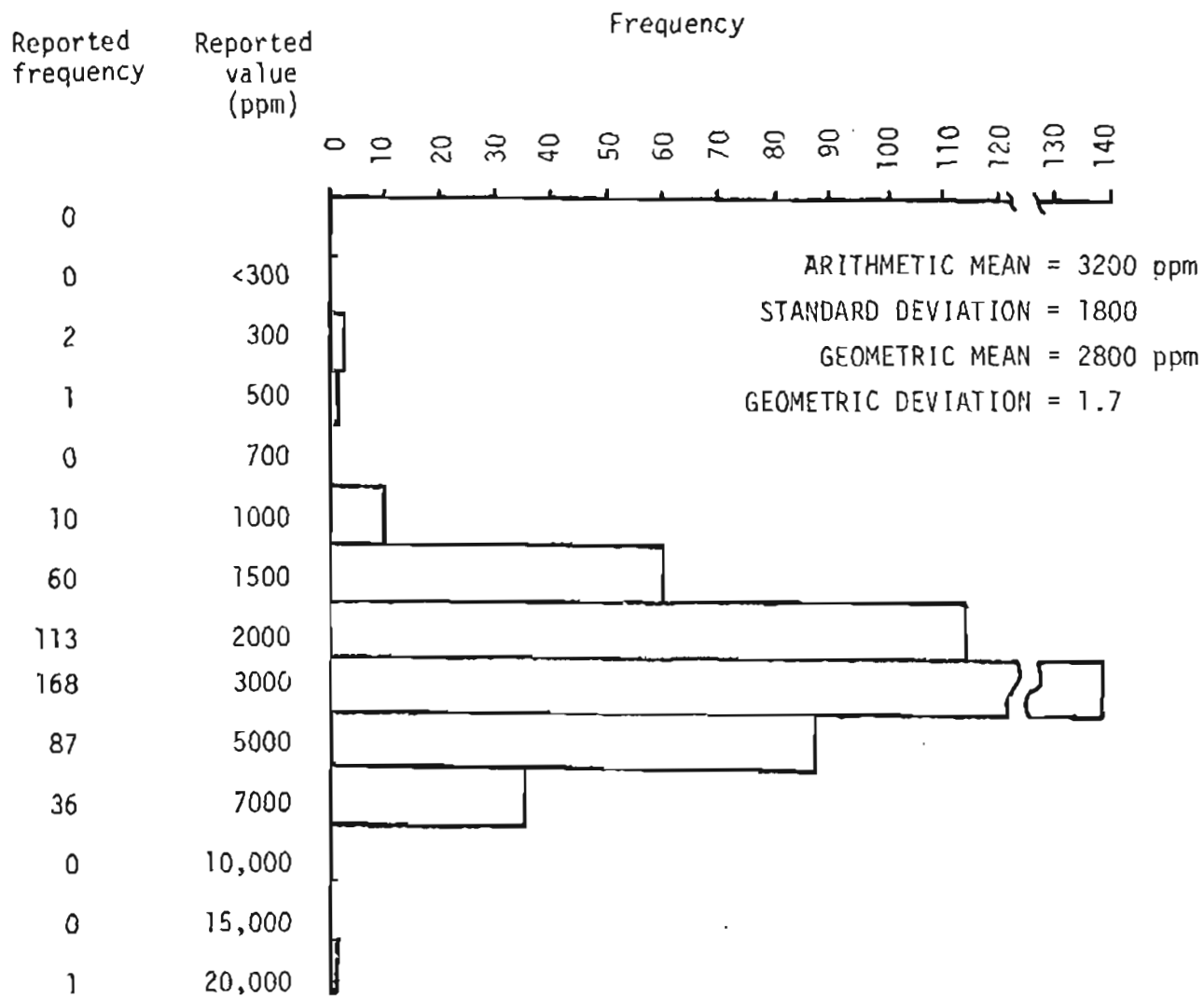

Figure 20.--Histogram showing zinc, in parts per million (ppm), in samples of the ash of ground birch leaves from the Tanacross quadrangle, Alaska.

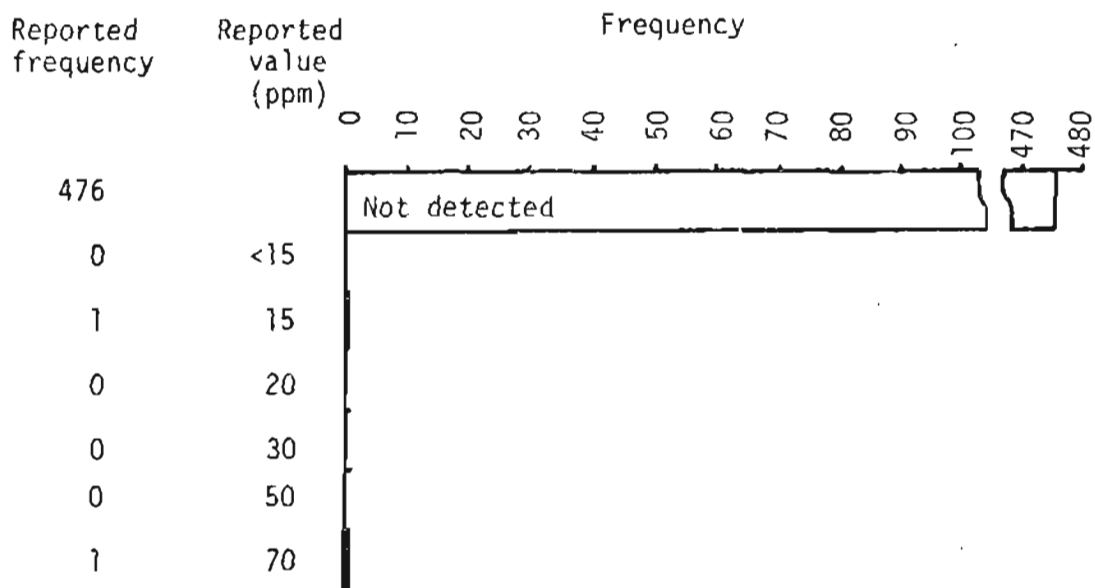

Figure 21.--Histogram showing zirconium, in parts per million (ppm), in samples of the ash of ground birch leaves from the Tanacross quadrangle, Alaska.

Table 1.--Simple linear correlation coefficients between logarithmic values of the element concentrations in the ash of 478 samples of ground birch leaves collected in the Tanacross quadrangle, Alaska.

[Upper half of the table contains correlation coefficients, multiplied by 100; lower half is the number of pairs of values used to compute coefficients. ***indicates correlation coefficient was not computed. Method of analysis (indicated in the row and column headings: S = Emission spectrography. Boldface figures indicate significant positive correlation.)

	S-FEX	S-MGX	S-TIX	S-MN	S-AG	S-AU	S-B	S-BA	S-CO	S-CO	S-CR	S-CU	S-MO	S-NI	S-PB	S-SR	S-V	S-W	S-ZN	S-ZR	
S-FEX	49	65	47	2	-27	47	19	27	8	15	-2	58	11	45	46	42	31	-27	30	-99	
S-MGX	22	20	-17	20	-20	-17	28	29	0	1	41	65	4	34	40	44	24	24	49	-99	
S-TIX	326	315	74	-8	-12	74	7	2	1	20	30	17	7	17	36	19	15	-75	13	-99	
S-MN	107	185	73	107	-10	73	28	35	23	14	-94	0	-16	22	-1	3	53	***	20	***	
S-AG	43	57	65	21	30	65	-13	-13	6	0	100	-23	-11	-4	-26	-1	-6	***	-12	***	
S-AU	5	5	5	3	5	5	8	49	25	***	***	-36	-1	63	21	63	-2	***	-10	***	
S-B	326	466	326	186	59	326	5	13	13	11	28	32	3	7	18	17	30	40	34	100	
S-BA	326	466	326	186	59	326	5	13	13	11	28	32	3	7	18	17	30	40	34	100	
S-CO	297	420	297	150	58	297	5	431	30	32	-57	-1	2	5	13	-10	49	-54	18	100	
S-CR	156	209	156	56	33	156	2	217	206	30	-45	11	13	22	19	-2	39	***	-4	***	
S-CU	13	13	14	3	2	14	14	14	14	8	30	20	6	-7	-24	77	-70	***	-58	***	
S-MO	261	338	261	94	46	261	5	350	332	173	14	350	4	4	11	7	0	0	4	***	
S-NI	326	466	326	186	59	326	5	478	431	217	14	478	350	30	19	29	7	-58	11	-99	
S-PB	326	466	326	186	59	326	5	478	431	217	14	478	350	30	19	29	7	-58	11	-99	
S-SR	323	459	323	183	59	323	5	471	426	215	14	471	347	47	471	30	1	6	32	-99	
S-V	326	466	326	186	59	326	5	478	431	217	14	478	350	478	478	471	47	47	14	-99	
S-W	4	4	4	2	0	4	5	5	4	4	0	5	5	5	5	5	5	30	18	***	
S-ZN	326	466	326	186	59	326	5	478	431	217	14	478	350	478	478	471	478	5	30	-99	
S-ZR	2	2	2	1	1	2	2	2	2	1	0	2	1	2	2	2	2	0	2	2	30
S-FEX	49	65	47	2	-27	47	19	27	8	15	-2	58	11	45	46	42	31	-27	30	-99	